

Configurational Entropy of Codimension-One Tilings and Directed Membranes

N. Destainville,¹ R. Mosseri,¹ and F. Bailly²

Received July 15, 1996; final December 18, 1996

The calculation of random tiling configurational entropy amounts to an enumeration of partitions. A geometrical description of the configuration space is given in terms of integral points in a high-dimensional space, and the entropy is deduced from the integral volume of a convex polytope. In some cases the latter volume can be expressed in a compact multiplicative formula, and in all cases in terms of binomial series, the origin of which is given a geometrical meaning. Our results mainly concern codimension-one tilings, but can also be extended to higher codimension tilings. We also discuss the link between free-boundary- and fixed-boundary-condition problems.

KEY WORDS: Quasicrystals; configurational entropy; partitions; random tilings.

1. INTRODUCTION

Quasicrystalline materials revealing exotic symmetries were discovered more than 10 years ago.⁽¹⁾ A great deal of work has been devoted to understanding their structure at the atomic level. Even though one can estimate that in the best cases only 70–80% of the atomic locations are known, this can already be seen as a success, considering the initial complexity of the problem. Among the many questions which are still open, the origin of the stability in these noncrystallographic metallic alloys is not clearly understood. However, several models have been proposed to explain this stability. One of the most popular consists in considering quasicrystals as particular instances of Hume-Rothery alloys.⁽⁶⁾ Indeed, these phases appear to be stabilized when their stoichiometry amounts to almost definite values

¹ Groupe de Physique du Solide, Université de Paris 7 et 6, 75251 Paris Cedex 05, France.

² Laboratoire de Physique du Solide-CNRS, 92195 Meudon Cedex, France.

for the ratio of electrons per atom. In the language of quasicrystals, this is associated with Fermi surfaces close to boundaries of pseudo-Brillouin zones, the latter being defined with respect to the most intense diffraction peaks.

A second often-considered explanation is that of an entropically stabilized material, the *random tiling model*.⁽¹²⁾ The underlying problem can be easily settled (as was initially done) under the simplifying assumption that the complexity of the structure is coded in the attangement of tiles (for instance, simple rhombi in 2D or rhombohedra in 3D). Once the best arrangement of tiles is found (e.g., which minimizes the free energy), the last step toward atomic models is made by an atomic decoration of the tiles. Note that this way of modeling the structure (with each cell of a given type receiving the same atomic decoration) does not exhaust all the possible atomic structures, but is believed to give plausible averaged structures. In the "maximally" random tiling model, the free energy only depends on its configurational entropy contribution, which amounts to a combinatorial problem. Note that, in the simplest case of rhombus tilings on a triangular grid (which is not strictly speaking related to quasicrystal problems, but retains part of their complexity), Blöte and Hilhorst⁽¹⁷⁾ showed that the entropy amounts to that of the ground state of an Ising antiferromagnet on a triangular lattice.

More realistic models should take into account an energy term that is a function of the tile configuration. There could even be a phase transition between a low-temperature phase, whose stability would be mostly driven by interaction energies (favoring a perfect quasicrystal order), and a higher temperature phase, entropically stabilized, whose disorder would nevertheless not destroy the Bragg-like diffraction peaks (in 3D) which are the signature of the quasiperiodic order.

Even though, on physical grounds, we do not particularly favor the entropic stabilization mechanism as opposed to the electronic quantum effect, we shall focus in this paper on the combinatorial problem which underlies this entropic model. Indeed, this problem of "statistical mechanics of tilings" appears to be extremely interesting. The paradigmatic models of quasicrystals are the Fibonacci chain in 1D, the Penrose tiling in 2D, and their generalized icosahedral versions in 3D.⁽⁴⁾ The standard method for generating these d -dimensional structures consists in a selection of sites and tiles in a D -dimensional ($D > d$) lattice according to certain rules, followed by a projection onto a suitable d -dimensional Euclidean subspace (we say that we have a $D \rightarrow d$ problem). A main difference between the quasiperiodic and the simplest crystalline arrangements (e.g., the periodic chain and square and cubic tilings in 1D, 2D, and 3D, respectively) is the possibility in the former of limited local rearrangements ("reshuffling") of

tiles. They are often called *localized phasons* or *elementary flips*. They give rise to huge numbers of very similar structures, and therefore to a configurational entropy term in the free energy.

We shall mainly ask the following question: given a certain polyhedral boundary in d dimensions, in how many ways is it possible to tile perfectly this polyhedron with d -dimensional rhombohedra? More specifically, we shall focus here on the simple codimension-one case, where, in the cut-and-project language, $D = d + 1$. However, many of the results presented here also apply to higher codimension problems. The polyhedron to be tiled will be the generic "shadow" of a D -dimensional rectangular parallelepiped whose edge sizes take integer lengths in the D -dimensional hypercubic lattice. The tiles in d dimensions will be the generic projections of the d -dimensional facets of the D -dimensional hypercubes. In the simple $3 \rightarrow 2$ case, this amounts to tiling hexagons of integral sides by unit rhombi. As a result, all the investigated tilings precisely correspond to those obtained through a standard grid method⁽⁹⁾ slightly modified (the grids are not necessarily straight) with a well-defined number of grids along each direction. In other words, the investigated tilings correspond to tilings that can be generated by a cut-and-project algorithm with a constrained selection algorithm (the sites are selected inside a given rectangular parallelepiped⁽¹⁰⁾ and some sites are fixed on the boundary). Note that all the tilings associated with quasicrystalline structures correspond to codimensions greater than one; we have already obtained some results in these more complicated cases.⁽¹¹⁾ But the codimension-one case is already very rich and is connected with several combinatorial distinct problems. Therefore, it deserves a separate presentation. A key to this combinatorial approach is the possibility to map tilings into combinatorial objects called *partitions*, as was done in the $3 \rightarrow 2$ case by Elser.⁽⁷⁾ Note that, owing to their relation to cut-and-project models, all these tilings can also be lifted into faceted *directed* d -dimensional membranes built on D -dimensional hypercubic lattices. By directed, we mean that, as for directed paths, their projection along a suitable direction creates neither gaps nor overlaps.

In order to evaluate the configurational entropy, we specify the polygonal or polyhedral boundary by D integers which fix the size and shape of the rectangular parallelepiped, and then let the size of this boundary increase, holding the shape fixed. Note that in this specific statistical mechanics problem the entropy depends on the boundary condition at the infinite-size limit, in a way that will be discussed below. In particular, the boundary condition associated with our combinatorial treatment gives a lower configurational entropy as compared to the free or periodic boundary conditions. That is why we have to be very careful with these boundary conditions and we explore below the relation between different ones.

In Section 2, we first recall briefly the link between partitions and tilings, not only for codimension-one tilings, but also for higher codimension tilings. We also explain the link between tilings and directed membranes (Section 2.5). In Section 3, we define the configuration space of this enumeration problem and its general properties. This configuration space is a convex polytope embedded in a space of very high dimension. Enumerating the tilings amounts to counting integral-coordinate points inside this convex polytope. Section 4 is devoted to presenting the tools which will prove useful in our study of the configuration space (Ehrhart polynomial, poset graph, etc.). The next two sections contain our main theoretical results: additive (Section 5) and multiplicative (Section 6) formulas. Finally, Section 7 gives results and conjectures about the configurational

Table I. Notations Used in This Paper

Notation	Section where defined	Definition
a_j	5.5.1	Number of simplices with j descents
D	1	Dimension of the lattice the membrane lies on
d	1	Dimension of the tiling (or membrane)
$D \rightarrow d$	1	Type of problem considered
$\mathcal{F}^{[K]}$	3.2	K -dimensional configuration space
$\mathcal{F}^{[q]}$	4.2	Any q -dimensional extremal face of $\mathcal{F}^{[K]}$
Φ	4.2	Bijection $T_{\mathcal{N}} \rightarrow V_{\mathcal{N}}$
$\mathcal{H}^{[K]}$	3.2	K -dimensional hypercube
$\mathcal{H}^{[q]}$	4.2	Any q -dimensional extremal face of $\mathcal{H}^{[K]}$
$\mathcal{H}(\mathcal{F})$	4.2	Mapping $T_{\mathcal{F}} \rightarrow T_{\mathcal{N}}$
K	3.1	Number of parts; dimension of $\mathcal{F}^{[K]}$
k_j	2.6	Side lengths of the boundary
$k!^{[m]}$	6.1	Generalized factorial of order m
$\cdot // = (a_{ij})$	5.2	Inclusion matrix
$\cdot \tilde{I}(X)$	5.3.2	Modified inclusion matrix
M	5.5.4	Maximum number of descents
$P_{\mathcal{F}^{[K]}(p)}$	4.1	Ehrhart polynomial of $\mathcal{F}^{[K]}$
$\mathcal{P}_{\mathcal{F}^{[K]}(X_q)}$	5.3.1	Polynomial $P_{\mathcal{F}^{[K]}}$ written in the basis $(X_q^k)_{k \in \mathbb{Z}}$
p	2.1	Maximum height of the parts
$\rho^{[q]}$	5	Any q -dimensional normal simplex
S_0	4.2	Point of coordinates $(p, p, \dots, p) \in \mathcal{F}^{[K]}$
$T_{\mathcal{F}}$	4.2	Set of extremal faces of $\mathcal{F}^{[K]}$
$T_{\mathcal{N}}$	4.2	Set of extremal faces of $\mathcal{H}^{[K]}$
$V_{\mathcal{F}}$	4.2	Set of vertices of $\mathcal{F}^{[K]}$
$V_{\mathcal{N}}$	4.2	Set of vertices of $\mathcal{H}^{[K]}$
W^{D-d}	5	Number of configurations
$X_q^n(p)$	4.1	Polynomial (ρ_q^{p+n})
x_i	3.1	Variables of a partition problem

entropy, in finite-size tilings as well as at the infinite-size limit. The link between free-boundary and fixed-boundary conditions is also established in this section (Section 7.4). Section 8 is devoted to conclusions. Table I lists our notation.

2. PARTITIONS AND TILINGS

2.1. Hypersolid Partitions and Generalized Partitions

Generally speaking, we define a *partition* as a family of K integers arranged in an array so that two numbers in two adjacent boxes of this array satisfy an order relation. If every relation is strong (resp. weak), the partition is said to be strong (resp. weak). These integers are taken between 0 and a given integer p (weakly for a weak partition and strongly for a strong partition). p is called the height of this partition.

If the array is a hypercubic array of dimension d and if the parts of the partition are decreasing in each of the d directions of space, we call it a *hypersolid* partition. For example, if $d = 1$, we have a linear partition, if $d = 2$, a plane partition (Fig. 1),⁽²¹⁾ and if $d = 3$, a solid partition.

If the order relations on the array are more general, we say that we have a *generalized* partition.

2.2. Hypersolid Partitions and Codimension-One Tilings

The mapping between tilings and partitions⁽³⁾ appears clearly when looking at the example of Fig. 2: this figure illustrates the mapping between $3 \rightarrow 2$ tilings and plane partitions. The rhombus tiling has a natural representation in a 3-dimensional space that can be seen as a plane partition of height p on a $k \times l$ rectangle. Conversely, the plane partition has a natural representation built on a cubic lattice in a 3-dimensional space, which is projected along the $(1, 1, 1)$ direction in order to get a tiling, with identical but differently oriented rhombi.

3	3	2
2	2	1
1	0	0

Fig. 1. Example of a plane partition: a plane partition of height $p = 3$ on a 3×3 rectangle. The integers are decreasing in each row and in each column (weakly).

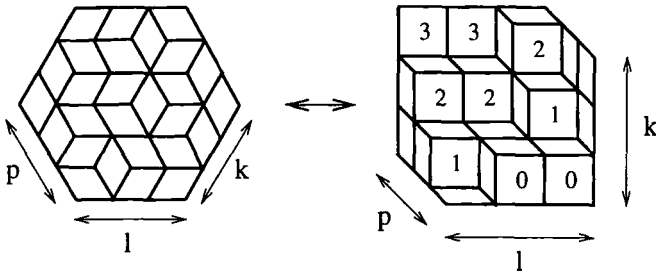

Fig. 2. Map: $\{3 \rightarrow 2 \text{ tilings}\} \rightarrow \{\text{plane partitions}\}$ (the plane partition is the same as the one in Fig. 1).

This can be generalized to arbitrary-dimension codimension-one tilings⁽¹⁰⁾: there is a natural map: $\{d + 1 \rightarrow d \text{ tilings}\} \rightarrow \{d\text{-dimensional partitions}\}$. Indeed, a $d + 1 \rightarrow d$ tiling has a natural representation in a $(d + 1)$ -dimensional space, which can be seen as a hypersolid partition. That is why we must count d -dimensional partitions in order to enumerate $d + 1 \rightarrow d$ tilings.

2.3. Boundary Conditions

The $3 \rightarrow 2$ example (Fig. 2) illustrates the fact that these tilings have a very specific boundary condition: here, we tile a hexagon. More generally speaking, the $d + 1 \rightarrow d$ tilings that we get by this method tile the projection of a $(d + 1)$ -dimensional rectangular parallelepiped along the $(1, 1, \dots, 1)$ direction. The polytopes resulting from such a projection form a standard set of space-filling zonotopes,⁽³²⁾ beginning with the hexagon in 2D and the rhombic dodecahedron in 3D. We shall discuss later the influence of this boundary when we study entropy at the infinite-size limit.

Note that this kind of fixed boundary condition for the tilings is a direct consequence of the standard definition for partitions. As will be discussed in Section 7, these tilings differ from those built with free or periodic boundary conditions. It is nevertheless possible to generalize the partitions in order to match closer the latter conditions, but at the price of highly complicating the analysis.

2.4. Greater Codimension Tilings

We shall consider here a specific example of generalized partitions. Indeed, as shown in ref. 11, a higher codimension tiling can be seen as a generalized partition on a partition, or, in other words, as a partition on a tiling. The number of steps in the construction depends on the codimension.

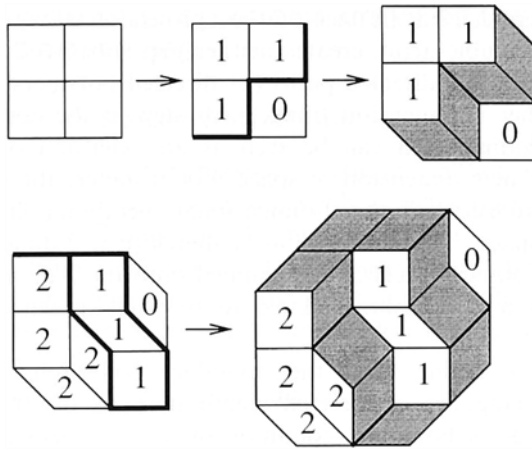

Fig. 3. A $4 \rightarrow 2$ tiling. Starting from a $2 \rightarrow 2$ tiling, the first step builds a $3 \rightarrow 2$ tiling (slightly deformed). The second step builds a $4 \rightarrow 2$ tiling.

For example, a $4 \rightarrow 2$ tiling is a partition on a Fig. 2-like tiling (left-hand side) with suitable order relations among the cells of this partition (Fig. 3) (this kind of tiling is related to the octagonal quasiperiodic tiling).

Note, however, that recent private discussion with V. Reiner raised some interesting questions on the one hand about the relation between our generalized partitions and the so-called P -partitions,^(35,36) and on the other hand about the relation between tilings and partitions in the cases $d \geq 3$ and $D - d \geq 2$. In particular, the ergodicity question, that is, the possibility to connect any two tilings by sequences of flips, may be not trivial in these cases.

Remark. On these tilings, p is a side length of the polygonal orpolyhedral boundary. It is artificially (and arbitrarily) singularized among the other side lengths in the partition point of view.

2.5. Directed Membranes

An important fact here is that these tilings can be lifted as d -dimensional nonflat structures embedded in D dimensions and then mapped onto a d -dimensional Euclidian space ($d < D$).

For a codimension-one tiling, this nonflat structure is a *membrane* made of d -dimensional facets of the \mathbf{Z}^{d+1} lattice. It is the natural representation of the partition associated with the tiling (for example, in Fig. 2, the representation of the plane partition can be seen as the projection of a 2-dimensional membrane in the 3-dimensional space). It is called a *directed*

membrane to emphasize the fact that its projection along the $(1, 1, \dots, 1)$ axis of the hypercubic array creates neither gaps nor overlaps. For $d=1$, one recovers the usual directed paths (or directed polymers).

For a higher codimension tiling, each step in the construction that increases the codimension can be seen as an extension of the previous membrane in a new dimension of space. For instance, the second step of Fig. 3 is an extension of the 2-dimensional membrane into the fourth dimension of space. The $4 \rightarrow 2$ tiling is therefore a 2-dimensional membrane, made of square facets of \mathbf{Z}^4 , mapped onto the 2-dimensional space. This construction is of course related to the well-known *cut-and-project* method.^(12, 14)

We have to define what the boundary conditions of Section 2.3 become in the language of directed membranes. As illustrated in Figs. 2 and 3, we also get a boundary condition in the D -dimensional space: the membrane is inscribed inside a (nonflat) polygon (or polyhedron), the projection of which on the d -dimensional space gives the tiling boundary. For instance, the boundaries of $3 \rightarrow 2$ or $4 \rightarrow 2$ tilings are (nonflat) 3-dimensional hexagons or 4-dimensional octagons. We shall call these boundaries the membrane *frames*.

2.6. Number of Tiles

In order to derive an entropy “per tile” we shall need in the following the number of tiles in the tilings under study. For a given boundary condition, this number of tiles does not depend on the tiling (elementary flips conserve the number of tiles): it is a function only of the side lengths of the boundary.

For a codimension-one tiling which fills the projection along the $(1, 1, \dots, 1)$ direction of a rectangular parallelepiped of side lengths k_1, k_2, \dots, k_{d+1} , using the fact that one kind of tile comes from one facet orientation in the membrane, and summing over the different kinds of tiles, one gets

$$\# \text{ tiles} = \sigma_d(k_1, k_2, \dots, k_{d+1})$$

where σ_d is the sum of all the products of d numbers among k_1, k_2, \dots, k_{d+1} .

Similarly, for any $D \rightarrow d$ problem, the number of tiles is

$$\# \text{ tiles} = \sigma_d(k_1, k_2, \dots, k_D)$$

where σ_d is now the sum of all the products of d numbers among the D integers k_1, k_2, \dots, k_D . In the diagonal cases (for any i , $k_i = k$), this reads $\# \text{ tiles} = \binom{D}{d} k^d$.

3. CODIMENSION ONE: CONFIGURATION SPACE AND GENERAL PROPERTIES

3.1. Configuration Space: Definitions

Let us focus now on hypersolid partitions, although most of the notions and properties we present also apply to generalized partitions. To simplify further, we will only consider weak partitions.

Since a partition is a family of K integers that satisfy a family of inequalities, if each value of a box is the value of a variable attached to this box, each partition is represented by an integral-coordinate point, or an *integral point*, in a K -dimensional space.

For example, if the 12 variables are set as

x_1	x_2	x_3	x_4
x_5	x_6	x_7	x_8
x_9	x_{10}	x_{11}	x_{12}

and if the plane partition is

3	3	2	1
3	2	0	0
1	1	0	0

then the partition is represented by the integral point:

$$\begin{cases} x_1 = 3; & x_2 = 3; & x_3 = 2; & x_4 = 1 \\ x_5 = 3; & x_6 = 2; & x_7 = 0; & x_8 = 0 \\ x_9 = 1; & x_{10} = 1; & x_{11} = 0; & x_{12} = 0 \end{cases}$$

in a 12-dimensional space.

Notation. The variable attached to the box of coordinates $\alpha_1, \dots, \alpha_d$ in the d -dimensional hypercubic array will sometimes be conveniently denoted by $x_{\alpha_1, \dots, \alpha_d}$ (for example, $x_1 = x_{1,1, \dots, 1}$, etc.). The size of the array in each direction is denoted k_i , to be consistent with the previous notation for the side lengths of the boundary.

3.2. Configuration Space: Convex Polytope in High Dimension

The above variables obey the inequality

$$x_i \geq x_j \tag{3.1}$$

where (i, j) denotes a couple of indices attached to adjacent boxes in the partition problem. In addition, one has

$$p \geq x_i \geq 0 \tag{3.2}$$

for each variable.

These inequalities define a *convex polytope* in a K -dimensional space. Indeed, each inequality defines a half-space and the intersection of all these half-spaces is a convex body, more precisely a convex polytope. This polytope will be denoted by $\mathcal{F}^{[K]}$. It is included in the hypercube $\mathcal{H}^{[K]}$ of vertices $\{(x_i)_{1 \leq i \leq K}, x_i \in \{0, p\}\}$.

To summarize, to each integral point of $\mathcal{F}^{[K]}$ there corresponds a set of K integers which satisfy the inequalities (3.1) and (3.2), an admissible partition and therefore biunivocally a tiling. Note here the important following point: the dimensionality K of the convex polytope is independent of p . When p varies, the external shape of the convex body is fixed, only its size varies. But, as will become clear in the following, since we are interested in a discrete feature on this convex polytope, it may require that p takes a minimal value in order that the complexity of this structure is fully taken into account (in particular when we dissect this polytope into simplices: Section 5).

Now, let us study the properties of this convex polytope more precisely.

3.3. Elementary Flips and Discrete Metric

Two adjacent integral points in the configuration space represent tilings which are very close. Indeed, these integral points only differ by one coordinate and this difference is equal to one. In terms of partitions, all their parts but one are equal. Then, the corresponding tilings differ by an *elementary flip*. Figure 4 shows such elementary flips in $3 \rightarrow 2$ and $4 \rightarrow 3$ tilings.

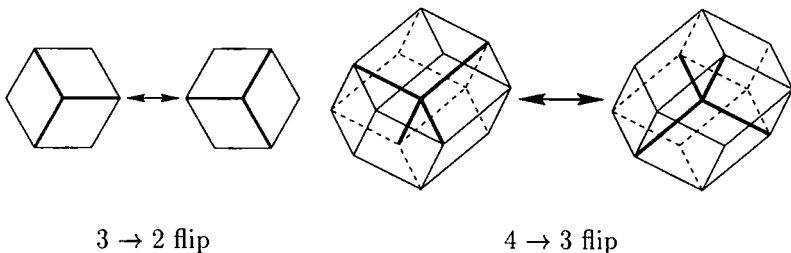

Fig. 4. Two example of codimension-one flips.

This property enables us to define an interesting *discrete metric* in the configuration space. Indeed, the “Manhattan” distance between two integral points in the convex polytope is the minimal number of elementary steps needed to go from the first point to the second one. Then, if one considers the two corresponding tilings, this distance represents the minimal number of elementary flips needed to go from the first tiling to the second one.

Moreover, all the different paths *in* the configuration space that go from a first integral point to another represent all the minimal sequences of elementary flips that link the two corresponding tilings. So this analysis in terms of partitions and configuration space gives an interesting representation of flip dynamics in random tilings, at least for codimension-one tilings. Note that the number of different flip paths going from one tiling to another is supposed to play an important role in the theory of self-diffusion in quasicrystals (P. Kalugin, private communication).

This discrete metric is a very interesting advantage of this partition approach of tilings. Indeed, in the tiling space, appropriate sequences of flips can move vertices arbitrarily small distances. But, in our configuration space, the corresponding tilings inherit a finite, discrete distance.

3.4. A Remark on the Shape of the Configuration Space

An important class of tilings are those whose boundary side lengths (including p) are approximately equal (for example, if we have a hypersolid partition on a $k_1 \times k_2 \times \dots \times k_d$ d -dimensional array, this corresponds to $k_1 \approx k_2 \approx \dots \approx k_d \approx p$).

Then, let us show that under these conditions, all the integral points in the convex polytope lie on its boundary (or, in other words, that its interior is empty of integral points). We therefore need to show that for any integral point in the convex polytope, at least one of the inequalities (3.1) or (3.2) between the x_i is in fact an equality. That is: all these inequalities cannot be simultaneously strong. Indeed, in the partition language, the two constraints that all the inequalities between the parts be strong *and* all these positive parts be strictly smaller than p are *not* compatible (excepted for very small values of the side lengths).

We shall see in Section 4 that this can be expressed in terms of roots of a particular polynomial. Note, however, that this is due to our boundary conditions: it is always possible to change them slightly in order to allow interior points. But this will not significantly alter the extremely elongated needle shape of this configuration space suggested by the zero integral volume of its interior.

3.5. The Simplest Example: Linear Partitions

Consider the linear (or one-dimensional) partition problem:

$$p \geq x_1 \geq x_2 \geq \dots \geq x_K \geq 0$$

Then the configuration space is a simplex, that is, the K -dimensional convex hull of $K + 1$ points. More precisely,

$$\mathcal{F}^{[K]} = \text{Conv}(A_0, A_1, \dots, A_K) \tag{3.3}$$

where A_k is the point of coordinates

$$\underbrace{(p, \dots, p, 0, \dots, 0)}_{k \text{ times}}$$

This convex polytope is denoted by $\mathcal{S}^{[K]}$. Section 4.2 and Fig. 5 provide an example.

Then we prove inductively on p that the integral volume of this simplex is $\binom{p+K}{K}$: for $K = 1$, $\text{Card}\{x \in \mathbf{Z}/p \geq x \geq 0\} = p + 1 = \binom{p+1}{1}$; and if the relation is true for a given K , then

$$\begin{aligned} &\text{Card}\{x_i \in \mathbf{Z}/p \geq x_1 \geq x_2 \geq \dots \geq x_{K+1} \geq 0\} \\ &= \sum_{x_1=0}^p \text{Card}\{x_i \in \mathbf{Z}/x_1 \geq x_2 \geq x_3 \geq \dots \geq x_{K+1} \geq 0\} \\ &= \sum_{x_1=0}^p \binom{x_1 + K}{K} \\ &= \binom{p + (K + 1)}{K + 1} \blacksquare \end{aligned}$$

This example, although rather trivial, will be useful in the following since this kind of simplex will appear as the fundamental component for the decomposition of general partition convex polytopes.

4. COUNTING INTEGRAL POINTS IN THE CONVEX POLYTOPE: TOOLS

Counting integral points in a convex polytope is a topic that has already been tackled by several mathematicians. Much progress has been made since the pioneering work of Ehrhart in 1964^(22,23) (for a general review, see ref. 24). However, there are still many unsolved questions.

Moreover, the convex bodies we are to study here are very particular among the large class of convex polytopes, and some specific tools will be developed. We shall first present briefly some standard combinatorial methods before detailing the more specific properties of our polytopes.

4.1. Ehrhart Polynomial and Reciprocity Law

Given a convex polytope \mathcal{F} , the fundamental property required to use the previously developed theories is that its vertices are themselves integral points.

Then, we can define $P_{\mathcal{F}}(p)$, the Ehrhart polynomial of \mathcal{F} . It gives the number of integral points that lie in $p\mathcal{F}$ [$=\{px, x \in \mathcal{F}\}$] (including its boundary), where p is an integer. This number of integral points is also called the *integral volume*. The polynomial character of the integral volume has been established by Ehrhart.^(22,24) Its degree is the dimensionality of \mathcal{F} . Note that $P_{\mathcal{F}}(0) = 1$.

This polynomial has a very nice property, called the *reciprocity law*:

Reciprocity Law. If the polytope \mathcal{F} is K -dimensional, if p is an integer, then $(-1)^K P_{\mathcal{F}}(-p)$ is the number of integral points in the interior of $p\mathcal{F}$ (i.e., excluding the boundary).

Remark. Thanks to the discussion of Section 3.4 about the interior of the convex polytope, we can claim that, with our boundary conditions, the values of p considered in Section 3.4 ($p \approx k_i$) are roots of the Ehrhart polynomial.

Note that if $\binom{p+K-k}{K}$ is understood as the polynomial function (even for negative values of p):

$$\binom{p+K-k}{K} = \frac{(p+K-k)(p+K-k-1)\cdots(p-k+1)}{K!} \tag{4.1}$$

then any polynomial $P_{\mathcal{F}(K)}(p)$ can be written likewise:

$$P_{\mathcal{F}(K)}(p) = \sum_{k=0}^K a_k \binom{p+K-k}{K} \tag{4.2}$$

with suitable a_k . [Indeed, let us prove that given a polynomial $P_{\mathcal{F}(K)}(p)$, the a_k may be chosen so that the two polynomial expressions of (4.2) are equal. Since the degrees of these expressions are K , it is sufficient to find the a_k so that the two expressions are equal for $K+1$ values p : $0, 1, \dots, K$. If $p=0$, all the binomial polynomials vanish, except the first, that is,

$\binom{0+K}{K} = 1$. Since $P_{\mathcal{F}^{[K]}}(0) = 1$, $a_0 = 1$. If $p = 1$, only the first two binomial polynomials have a nonzero value: we must have $P_{\mathcal{F}^{[K]}}(1) = a_0 \binom{K+1}{K} + a_1$. Knowing $P_{\mathcal{F}^{[K]}}(1)$, we hence get the value of a_1 . We understand that, inductively, it will be possible to choose all the values of the a_k by setting successively p to the values $0, 1, \dots, K$. We note here that the a_k are integers.]

Notation. For reasons that will appear later, we shall write $\binom{p+n}{K} = X_K^n(p)$, so that

$$P_{\mathcal{F}^{[K]}}(p) = \sum_{k=0}^K a_k X_K^{K-k}(p)$$

4.2. Specific Definitions

If S_0 is the point (p, p, \dots, p) of the hypercube $\mathcal{H}^{[K]}$, we propose the following definitions:

Extremal Face of the Hypercube. A face \mathcal{H} (of any dimension) of the hypercube $\mathcal{H}^{[K]}$ is called an *extremal face* if it contains S_0 .

Extremal Face of the Convex Polytope. A face \mathcal{F} of the convex polytope $\mathcal{F}^{[K]}$ is called an *extremal face* if there exists an extremal face of $\mathcal{H}^{[K]}$ of the same dimensionality as the face \mathcal{F} that contains \mathcal{F} . We will denote by $\mathcal{H}(\mathcal{F})$ this face of $\mathcal{H}^{[K]}$.

We shall see later that these extremal faces are deeply related to the structure of the convex polytope.

Notations. $T_{\mathcal{H}}$ (resp. $T_{\mathcal{F}}$) is the set of the extremal faces of $\mathcal{H}^{[K]}$ (resp. $\mathcal{F}^{[K]}$). $V_{\mathcal{H}}$ (resp. $V_{\mathcal{F}}$) is the set of the vertices of $\mathcal{H}^{[K]}$ (resp. $\mathcal{F}^{[K]}$) (note that here, by vertices, we restrict consideration to the integral points which are at the extremities of the edges).

$\mathcal{H}^{[q]}$ (resp. $\mathcal{F}^{[q]}$) is any q -dimensional extremal face of $\mathcal{H}^{[K]}$ (resp. $\mathcal{F}^{[K]}$). The role of the exponent q is to specify the dimensionality of the face. It does not single out any q -dimensional face among the others. Note that $\{S_0\} = \mathcal{H}^{[0]} = \mathcal{F}^{[0]}$ and that $\mathcal{H}^{[K]}$ and $\mathcal{F}^{[K]}$ are themselves extremal faces. These faces being the only 0-dimensional or K -dimensional faces of the cube or of the convex polytope, the notation is here perfectly unambiguous.

We also define the *weight* of a vertex: it is the sum of its coordinates.

Example. Examine the $2 \rightarrow 1$ case: $p \geq x_1 \geq x_2 \geq x_3 \geq 0$. With the above notation, $K = 3$. $\mathcal{F}^{[K]}$ is a tetrahedron and $\mathcal{H}^{[K]}$ is a 3-cube

(Fig. 5). Moreover, $V_{\mathcal{F}} = \{(0, 0, 0), (p, 0, 0), (p, p, 0), (p, p, p)\}$. These elements are of respective weights $0, p, 2p, 3p$. And $T_{\mathcal{F}}$ contains for following four sets: the vertex (p, p, p) , the edge $\{(p, p, 0), (p, p, p)\}$, the triangle $\{(p, 0, 0), (p, p, 0), (p, p, p)\}$, and the tetrahedron itself. Note that, for instance, the face $x_2 = p$ does not contain an extremal face of $\mathcal{F}^{[3]}$, since it is 2-dimensional and its intersection with $\mathcal{F}^{[3]}$ is only 1-dimensional.

We can now define the map Φ , which will prove to play a fundamental role in the following (see Section 5.4):

$$\Phi: \begin{cases} T_{\mathcal{F}} \rightarrow V_{\mathcal{F}} \\ \mathcal{H}^{[q]} \mapsto \text{vertex of } \mathcal{H}^{[q]} \text{ of minimum weight} \end{cases} \quad (4.3)$$

This minimum-weight vertex, called the origin of $\mathcal{H}^{[q]}$, is the point of the face that is the closest to the origin of the space O . Then, one can easily check that Φ is bijective and that

$$\Phi^{-1}: (x_1, \dots, x_K) \in V_{\mathcal{F}} \mapsto \{(y_1, \dots, y_K) \in \mathcal{H}^{[K]} / \forall i, y_i \geq x_i\} \quad (4.4)$$

Note that Φ is an isomorphism between the posets (partially ordered sets) $(T_{\mathcal{F}}, \subset)$ and $(V_{\mathcal{F}}, \geq)$ in which if $(x_1, \dots, x_K), (y_1, \dots, y_K) \in V_{\mathcal{F}}$, then $(x_1, \dots, x_K) \geq (y_1, \dots, y_K)$ if and only if $\forall i, x_i \geq y_i$. It is worth emphasizing that this order relation will also play quite an important role below.

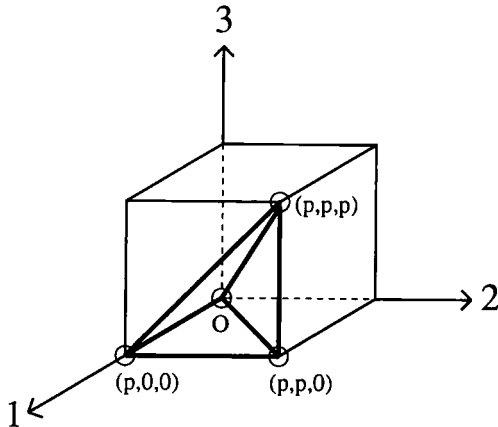

Fig. 5. The convex polytope of the $2 \rightarrow 1$ problem: $x_1 \geq x_2 \geq x_3$.

Now, we have the following property, which establishes a one-to-one correspondence between the extremal faces and the vertices of $\mathcal{F}^{[K]}$: Φ can be restricted to a bijection between $T_{\mathcal{F}}$ and $V_{\mathcal{F}}$. Not only does “restricted” mean that the bijection is between the restricted sets $T_{\mathcal{F}}$ and $V_{\mathcal{F}}$, but also that the extremal faces of the hypercube are restricted to extremal faces of the polytope [this last technical consideration comes from the fact that even if $\mathcal{F} \subset \mathcal{H}(\mathcal{F})$, \mathcal{F} might be different from $\mathcal{H}(\mathcal{F})$].

In other words, the above property means that a face of $\mathcal{F}^{[K]}$ is an extremal face if and only if its origin is a vertex of $\mathcal{F}^{[K]}$. Or that Φ induces an isomorphism between $(T_{\mathcal{F}}, \subset)$ and $(V_{\mathcal{F}}, \geq)$.

Let us now prove it: let $\mathcal{F}^{[q]}$ be a q -dimensional extremal face. $\mathcal{H}(\mathcal{F}^{[q]})$ (that is, the extremal face of $\mathcal{H}^{[K]}$ containing $\mathcal{F}^{[q]}$) is defined by some relations $x_i = p$ for $i \in I_0 \subset \{1 \dots K\}$ [$\text{Card}(I_0) = K - q$], and for $j \notin I_0$, $x_j \in [0, p]$. If for some $i \in I_0$ and some $j \in \{1 \dots K\} - I_0$, there existed an Eq. (3.1)-like inequality $x_i \leq x_j$, then we would get $x_j = p$ and $\mathcal{F}^{[q]}$ would no longer be a q -dimensional extremal face. Then no such inequality $x_i \leq x_j$ holds. Hence $\mathcal{F}^{[q]}$ is defined by $x_i = p$ for $i \in I_0$ and by inequalities between the remaining variables x_j . Then the origin of $\mathcal{H}(\mathcal{F}^{[q]})$, the coordinates of which are $x_i = p$ for $i \in I_0$ and $x_j = 0$ otherwise, also belongs to $\mathcal{F}^{[q]}$. It is therefore a vertex of $\mathcal{F}^{[K]}$.

Conversely, it can be checked in a similar way that a vertex of the convex is always an origin of an extremal face of $\mathcal{H}^{[K]}$.

For instance, in the above example, the origin of the triangular extremal face is the vertex $(p, 0, 0)$. As far as the poset $(V_{\mathcal{F}}, \geq)$ is concerned, note that it does not depend on the value of p , since its shape does not depend on p (see the end of Section 3.2). We denote this poset (or its graph) by T .

4.3. Structure of the Graph T

Our aim here is to describe the structure of the graph of the poset T of a given partition problem. We will show that this structure is deeply related to the convex polytope of a partition problem of lower dimension. This rather subtle relation will be at the heart of our powerful algorithm to compute the integral volumes of configuration spaces, as will be shown in the following.

First of all, it is necessary to understand the link between the $d + 1 \rightarrow d$ case with $p = 1$ and the corresponding $d \rightarrow d - 1$ case.

Here we use again the notation defined at the beginning of Section 3.1: x_{x_1, \dots, x_d} instead of x_i . Remember that x_{x_1, \dots, x_d} is the variable of the box of coordinates $\alpha_1, \dots, \alpha_d$ in the original d -dimensional space.

If $p = 1$, then, given (x_{x_1, \dots, x_d}) , each of them in $\{0, 1\}$, we define new coordinates $X_{x_1, \dots, x_{d-1}}$: if $\alpha_1, \dots, \alpha_d$ are fixed, $X_{x_1, \dots, x_{d-1}}$ is the number of variables $x_{x_1, \dots, x_{d-1}, \alpha_d}$, $\alpha_d = 1, \dots, k_d$, that are equal to 1, i.e.,

$$X_{x_1, \dots, x_{d-1}} = \sum_{\alpha_d=1}^{k_d} x_{x_1, \dots, x_{d-1}, \alpha_d}$$

Figure 6 shows an example of such a situation: here $d = 2$. The $3 \rightarrow 2$ case with $p = 1$ becomes a $2 \rightarrow 1$ case.

One understands that the X_i define a new $(d - 1)$ -partition of height k_d because if

$$(\alpha_1, \dots, \alpha_{d-1}) \leq (\alpha'_1, \dots, \alpha'_{d-1}) \quad (\text{that is, } \forall i, \alpha_i \leq \alpha'_i)$$

then for all $\alpha_d \in \{1, \dots, k_d\}$,

$$X_{x'_1, \dots, x'_{d-1}, \alpha_d} \geq X_{x_1, \dots, x_{d-1}, \alpha_d}$$

then

$$\sum_{\alpha_d=1}^{k_d} X_{x'_1, \dots, x'_{d-1}, \alpha_d} \geq \sum_{\alpha_d=1}^{k_d} X_{x_1, \dots, x_{d-1}, \alpha_d}$$

and finally

$$X_{x'_1, \dots, x'_{d-1}} \geq X_{x_1, \dots, x_{d-1}}$$

Conversely, given the $X_{x_1, \dots, x_{d-1}}$, the x_i are defined by $x_{x_1, \dots, x_d} = 1$ for $\alpha_d = 1, \dots, X_{x_1, \dots, x_{d-1}}$ and $x_{x_1, \dots, x_d} = 0$ for $\alpha_d = X_{x_1, \dots, x_{d-1}} + 1, \dots, k_d$.

Now, it must be understood that the vertices of the graph T [that is, the graph of the poset $(V_{\mathcal{F}}, \leq)$, or $(V_{\mathcal{F}}, \geq)$] are exactly the vertices of the $d \rightarrow d - 1$ convex polytope. Indeed, in T , two vertices A and B are linked if the former is greater than the latter and more precisely if A is just above B . This means that $A < B$ and if $A \leq C \leq B$, then either $C = A$ or

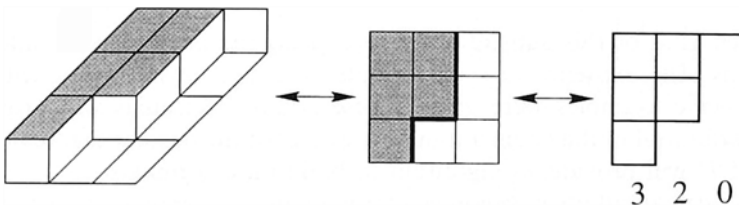

Fig. 6. The $3 \rightarrow 2$ partition with $p = 1$ and the corresponding $2 \rightarrow 1$ partition.

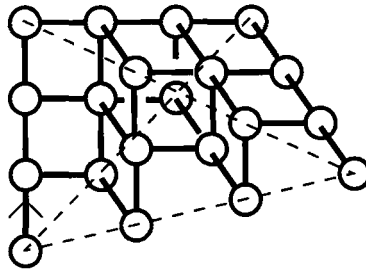

Fig. 7. Graph of a $3 \rightarrow 2$ problem $k = l = 3$: its vertices are the integral points of the 3-dimensional simplex of side 3 of the $2 \rightarrow 1$ problem in the case $k = 3$. The arrow on the graph indicates the direction of the order relation.

$C = B$. Let us recall that the graph does not depend on p . Hence take $p = 1$. In this case, it becomes clear that $A(x_1, \dots, x_K)$ is just above $B(y_1, \dots, y_K)$ if and only if there is a unique $(\alpha_1, \dots, \alpha_d)$ such that $x_{(x_1, \dots, x_d)} \neq y_{(x_1, \dots, x_d)}$ and then $x_{(x_1, \dots, x_d)} = 0$ and $y_{(x_1, \dots, x_d)} = 1$. [Indeed, if there should exist two $(\alpha_1, \dots, \alpha_d)$ and $(\beta_1, \dots, \beta_d)$ such that $x_{(x_1, \dots, x_d)} \neq y_{(x_1, \dots, x_d)}$ and $x_{(\beta_1, \dots, \beta_d)} \neq y_{(\beta_1, \dots, \beta_d)}$, the values would be $x_{(x_1, \dots, x_d)} = 0$, $x_{(\beta_1, \dots, \beta_d)} = 0$, $y_{(x_1, \dots, x_d)} = 1$, and $y_{(\beta_1, \dots, \beta_d)} = 1$. Then the point $C(z_1, \dots, z_K)$ such that $z_{(x_1, \dots, x_d)} = 0$ and $z_{(\beta_1, \dots, \beta_d)} = 1$ would satisfy $A < C < B$, which cannot be.]

Concerning the X_i , one gets $X_{(x_1, \dots, x_{d-1})} = Y_{(x_1, \dots, x_{d-1})} - 1$ and $X_j = Y_j$ for the other variables. This means that the corresponding points of the convex polytope of the $d \rightarrow d - 1$ case are *two neighbor points linked by a bond of the hypercubic lattice*.

Hence, *the graph of the $d + 1 \rightarrow d$ case is the set of integral points of the convex polytope of the $d \rightarrow d - 1$ case, these points being linked by the natural bonds of the lattice*. The side of this polytope is k_d .

Figure 7 illustrates the above property.

5. COUNTING INTEGRAL POINTS IN THE CONVEX POLYTOPE: ADDITIVE FORMULAS

The goal of this subsection is to explain the occurrence of additive formulas. The existence of such formulas was previously mentioned^(10,11) and specific examples were given. These additive formulas will prove to be a useful tool in the enumerating process, since the descent theorem (Section 5.5.2) will provide an algorithm to build these formulas.

We call an additive (binomial) formula an exact enumeration of partitions written as a sum of binomial coefficients. For example, if the number

of partitions of any $D \rightarrow d$ problem is denoted by $W^{D \rightarrow d}$, then the Ehrhart polynomial of the $3 \rightarrow 2$ problem $k = 3, l = 5$ is

$$\begin{aligned} \bullet W_{3,5}^{3 \rightarrow 2} &= \binom{15+p}{15} + 40 \binom{14+p}{15} + 400 \binom{13+p}{15} + 1456 \binom{12+p}{15} \\ &\quad + 2212 \binom{11+p}{15} + 156 \binom{10+p}{15} + 400 \binom{9+p}{15} \\ &\quad + 40 \binom{8+p}{15} + \binom{7+p}{15} \end{aligned}$$

For the $4 \rightarrow 2$ problem $k = 2, l = 2, m = 3$, one finds

$$\begin{aligned} \bullet W_{2,2,3}^{4 \rightarrow 2} &= 50 \binom{p+16}{16} + 1281 \binom{p+15}{16} + 9775 \binom{p+14}{16} \\ &\quad + 32304 \binom{p+13}{16} + 53175 \binom{p+12}{16} + 46343 \binom{p+11}{16} \\ &\quad + 22095 \binom{p+10}{16} + 5755 \binom{p+9}{16} + 774 \binom{p+8}{16} \\ &\quad + 47 \binom{p+7}{16} + \binom{p+6}{16} \end{aligned}$$

Similarly, the Ehrhart polynomial of the $4 \rightarrow 3$ problem $k = l = m = 2$ is

$$\bullet W_{2,2,2}^{4 \rightarrow 3} = \binom{p+8}{8} + 11 \binom{p+7}{8} + 24 \binom{p+6}{8} + 11 \binom{p+5}{8} + \binom{p+4}{8}$$

As will become clear below, these additive formulas have a simple geometrical meaning: counting partitions amounts to counting integral points in a convex polytope; this polytope is dissected into particular simplices, which are then enumerated; and the numbers of integral points in these simplices are given by binomial coefficients. Two main cases are discussed. Either every simplex has the same dimensionality K , the dimensionality of the convex polytope itself, and varying edge lengths, or the simplices have varying dimensionalities.

Since this section contains tedious calculations, it is built so that the reader can first skip Sections 5.1–5.4, which contain rather technical points, while going on to the rest of this paper. Moreover, several technical proofs are given in Appendix A.

We first develop recursive geometrical formulas which give hints about the inner structure of the convex polytope.

Then we build an *inclusion matrix* and develop a first algorithm to count integral points: the *inclusion matrix method*. This algorithm is then interpreted in terms of simplices. Only these last geometrical results are exposed in Section 5.5.

We need the following definitions:

***K*-Dimensional Normal Simplex.** Let E be a K -dimensional Euclidean space in which the tiling configuration space is embedded. Let $(\mathbf{e}_1, \mathbf{e}_2, \dots, \mathbf{e}_K)$ be the orthonormal basis of E which generates the \mathbf{Z}^K lattice. A *K-dimensional normal simplex* of side $s \in \mathbf{N}$ is a simplex $\text{Simp}(A_0, A_1, \dots, A_K)$ such that:

- Each A_i is an integral point.
- $(A_i A_{i+1})_{i=0, \dots, K-1}$ is an orthogonal family.
- $A_i A_{i+1}$ is parallel to a vector \mathbf{e}_k for any i .
- $\|A_i A_{i+1}\| = s$ for any i .

Note that, up to translations, there are $K!$ different such normal simplices of a given side length. They correspond to all the possible permutations of the basis vectors. One of them is the convex polytope of the linear partition problem $p \geq x_1 \geq x_2 \geq \dots \geq x_K \geq 0$.

***q*-Dimensional Normal Simplex.** Let $q < K$ be an integer. A *q-dimensional normal simplex* is a q -dimensional face of a K -dimensional normal simplex.

We prove in Appendix A.1 that the Ehrhart polynomial $P_{\mathcal{S}^{[q]}(s)}$ of any q -dimensional normal simplex $\mathcal{S}^{[q]}$ is

$$P_{\mathcal{S}^{[q]}(s)} = \binom{q+s}{q}$$

The idea of the proof is essentially that the integral volume of such a simplex is the same as the integral volume of the convex polytope of a suitable linear partition problem.

5.1. Recursive Formulas

Let us give a first recursive formula which links the integral volume of any face $\mathcal{F}^{[q]}$ with the integral volume of its extremal subfaces:

First Recursive Formula. Let $\mathcal{F}^{[q]}$ be any q -dimensional extremal face of $\mathcal{F}^{[K]}$. Then

$$P_{\mathcal{F}^{[q]}}(p) = \sum_{\mathcal{F}^{[r]} \in T_{\mathcal{F}^{[q]}}} P_{\mathcal{F}^{[r]}}(p-1) \tag{5.1}$$

That is, the Ehrhart polynomial for any extremal face is simply the sum of the Ehrhart polynomials (with p decreased by one) of the extremal face itself and its extremal subfaces.

To prove the above formula, it is convenient to prove it first for the hypercube itself. Let us denote by \mathcal{A}_α the set of elements of $\mathcal{H}^{[K]}$ that have exactly α coordinates equal to p (\mathcal{A}_0 is the hypercube itself with edge length reduced by one). Then

$$\mathcal{H}^{[K]} = \bigcup_{\alpha=0}^{\text{disj.}}^K \mathcal{A}_\alpha$$

It is less evident to realize that the number of integral points in \mathcal{A}_α (which we denote for simplicity $P_{\mathcal{A}_\alpha}$) satisfies

$$P_{\mathcal{A}_\alpha} = \sum_{\mathcal{H}^{[K-\alpha]}} P_{\mathcal{H}^{[K-\alpha]}}(p-1)$$

which proves the formula for the hypercube.

From a combinatorial point of view, the formula arises from writing $p^K = (1 + (p-1))^K$ and noting that the number of α -dimensional extremal faces of a K -dimensional hypercube is given by $\binom{K}{\alpha}$.

Now, the above recursive formula for $\mathcal{F}^{[K]}$ arises from the formula for the hypercube $\mathcal{H}^{[K]}$ by considering the definition of extremal faces of $\mathcal{F}^{[K]}$ and intersections between $\mathcal{F}^{[K]}$ and $\mathcal{H}^{[K]}$.

Figure 8 illustrates this first formula in the case where $\mathcal{F}^{[3]}$ is a tetrahedron, already discussed in Section 4.2.

Now, it must be emphasized that an extremal face is nothing but a particular case of the general convex polytope $\mathcal{F}^{[K]}$. Indeed, when we stressed the link between extremal faces and their origins (Section 4.2), we saw that the “free” variables (x_i such that $i \notin I_0$) obey inequalities, exactly as in the general case. That is why we can use the Ehrhart polynomial of an extremal face and the notation $T_{\mathcal{F}^{[q]}}$. Moreover, the above proof for $\mathcal{F}^{[K]}$ can easily be adapted to obtain the first recursive formula for any q -dimensional extremal face.

In the above formula, the problem of multiple counting was treated in terms of a disjoint union and therefore in terms of a sum of positive terms.

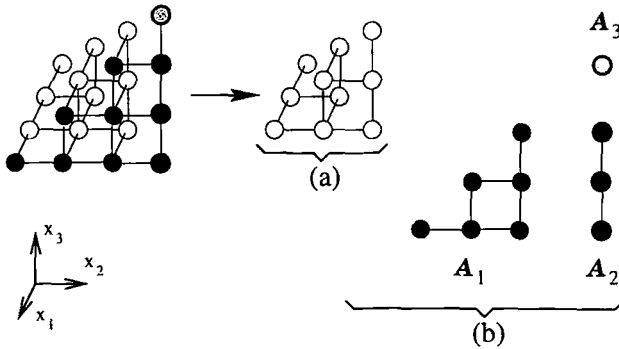

Fig. 8. The integral points in $\mathcal{F}^{[3]}$ (see again the example of Section 4.2) for $p=3$ are either in the convex polytope defined by $p=2$ (a) or have at least one coordinate equal to 3 (b). In this latter case, the points have one, two, or three coordinates equal to 3 and are then respectively in \mathcal{A}_1 , \mathcal{A}_2 , or \mathcal{A}_3 (note that we have extended here the notation \mathcal{A}_x to the sets of elements of $\mathcal{F}^{[K]}$ that have exactly x coordinates equal to p). Then $P_{\mathcal{F}^{[K]}(3)} = P_{\mathcal{F}^{[K]}(2)} + \text{Card}(\mathcal{A}_1) + \text{Card}(\mathcal{A}_2) + \text{Card}(\mathcal{A}_3)$.

But it is possible to write a similar formula in terms of an alternating sum, via the inclusion and exclusion principle,⁽³⁰⁾ in a way that will not be discussed here.

As a conclusion, this method provides a first algorithm to compute the first values of $P_{\mathcal{F}^{[K]}(p)}$ with a recursive method, the recursion index being p :

- If $p=0$, for all $\mathcal{F}^{[q]}$, $P_{\mathcal{F}^{[q]}(0)} = 1$.
- Suppose all the $P_{\mathcal{F}^{[q]}(p_0)}$ are known for a given p_0 and for all $\mathcal{F}^{[q]}$ (the extremal subfaces of $\mathcal{F}^{[K]}$). Using the graph T and the recursive formula, one can calculate successively the $P_{\mathcal{F}^{[q]}(p_0+1)}$ for $q=0, \dots, K$.

5.2. The Inclusion Matrix

Let \mathcal{F}_i be another notation for $\mathcal{F}^{[q]}$ with the following indexing rule: if $\mathcal{F}_i \subset \mathcal{F}_j$, then $i > j$. For example, $\mathcal{F}_1 = \mathcal{F}^{[K]}$ and if N is the number of extremal faces, $\mathcal{F}_N = \{S_0\}$. We denote by P_i the Ehrhart polynomial of \mathcal{F}_i .

Inclusion Matrix. The inclusion matrix $\mathcal{M} = (a_{ij})$ is an $N \times N$ matrix such that if $\mathcal{F}_j \subset \mathcal{F}_i$, then $a_{ij} = 1$, and otherwise $a_{ij} = 0$.

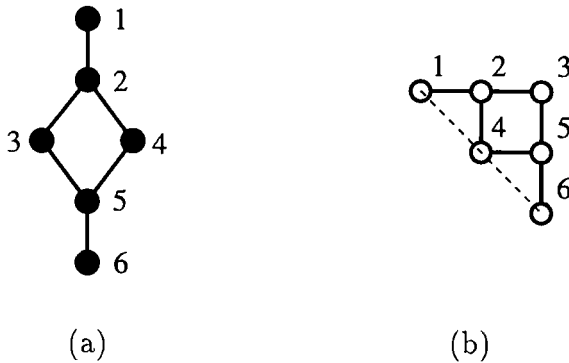

Fig. 9. (a) An example of the graph associated with a partition problem. The indices of the vertices are the indices of the corresponding faces. A face is contained in the above face in the graph. (b) As stressed in Section 4.3, this graph is equivalent to the convex polytope of the $2 \rightarrow 1$ problem $k = p = 2$, which consists of integral points inside a triangle of side 2.

Example. If one considers the graph (which corresponds to the $3 \rightarrow 2$ case with $k_1 = k_2 = 2$) of Fig. 9, the inclusion matrix is

$$\mathcal{M} = \begin{pmatrix} 1 & 1 & 1 & 1 & 1 & 1 \\ 0 & 1 & 1 & 1 & 1 & 1 \\ 0 & 0 & 1 & 0 & 1 & 1 \\ 0 & 0 & 0 & 1 & 1 & 1 \\ 0 & 0 & 0 & 0 & 1 & 1 \\ 0 & 0 & 0 & 0 & 0 & 1 \end{pmatrix}$$

Then, according to the first recursive formula (5.1), we have the following result:

$$\begin{pmatrix} P_1(p) \\ P_2(p) \\ \vdots \\ P_N(p) \end{pmatrix} = \mathcal{M} \times \begin{pmatrix} P_1(p-1) \\ P_2(p-1) \\ \vdots \\ P_N(p-1) \end{pmatrix}$$

and then

$$\begin{pmatrix} P_1(p) \\ P_2(p) \\ \vdots \\ P_N(p) \end{pmatrix} = \mathcal{M}^p \times \begin{pmatrix} P_1(0) \\ P_2(0) \\ \vdots \\ P_N(0) \end{pmatrix} = \mathcal{M}^p \times \begin{pmatrix} 1 \\ 1 \\ \vdots \\ 1 \end{pmatrix} \tag{5.2}$$

5.3. Development of the Inclusion Matrix Method

5.3.1. New Polynomial Formalism. We present here a first approach toward the coefficients a_k (introduced in Section 4.1), using the inclusion matrix and later a modified inclusion matrix.

Recall that $X_q^{q-k}(p) = \binom{p+q-k}{q}$. The key idea in this section will be to build new polynomials, in the variables X_q , associated with the extremal faces. We shall see that these polynomials also follow a recursive formula, which can be put in a matrix form.

Even though it is wrong to write $X_q^k \cdot X_q^l = X_q^{k+l}$, we shall give a meaning to the product of such polynomials. [The exact reason for the above prohibition is that the morphism $\binom{p+q-k}{q} \rightarrow X_q^{q-k}$, which transforms polynomials in p into polynomials in X_q , is a vector space morphism and not an algebra morphism.]

Given the formula

$$\binom{p+n}{q} + \binom{p+n}{q+1} = \binom{p+n+1}{q+1}$$

we let $X_q^n = (X_{q+1}^{n+1} - X_{q+1}^n)$. We can then legalize the writing

$$X_q^n = (X_{q+1} - 1) X_{q+1}^n \tag{5.3}$$

taking care that it is not a real product of the corresponding polynomials in p .

If a polynomial $P_{\mathcal{F}(q)}$ is written in terms of the X_q^{q-k} and if we want to write it in terms of the X_{q+1}^{q+1-k} , we must then use the substitution defined by Eq. (5.3). More generally, for any $q_0 > 0$, we have the following substitution equation:

$$X_q^n = (X_{q+q_0} - 1)^{q_0} X_{q+q_0}^n \tag{5.4}$$

which is related to the following identity between binomial coefficients:

$$\binom{p+n}{q} = \sum_{l=0}^{q_0} (-1)^{q_0-l} \binom{q_0}{l} \binom{p+n+l}{q+q_0}$$

Note again that one must be cautious with these notations. Indeed, we could be led to write $X_q^n = (X_{q+1} - 1) X_{q+1}^n$ and $X_{q+1}^n = (X_{q+2} - 1) X_{q+2}^n$. Hence $X_q^n = (X_{q+1} - 1)(X_{q+2} - 1) X_{q+2}^n$. Now, $X_{q+1} = (X_{q+2} - 1) X_{q+2}$. Replacing X_{q+1} by its value, we would get $X_q^n = (X_{q+2}^2 - X_{q+2} - 1) (X_{q+2} - 1) X_{q+2}^n$, which is wrong. The only legal formula is Eq. (5.4), and it must not be used in a product of polynomials, but only after having written this polynomial as a sum of monomials.

Thanks to Eq. (5.4), we can write now

$$\sum_k a_k X_q^k = \sum_k a_k (X_{q+q_0} - 1)^{q_0} X_{q+q_0}^k = (X_{q+q_0} - 1)^{q_0} \sum_k a_k X_{q+q_0}^k \quad (5.5)$$

The interest of this equation is that it can be used to write in another way the first recursive formula (5.1). We need first to introduce a new notation: if the polynomial $P_{\mathcal{F}^{[q]}}$ is written in terms of elementary polynomials X_q^k [i.e., in the basis $(X_q^k)_{k \in \mathbb{Z}}$], $P_{\mathcal{F}^{[q]}}(p) = \sum \alpha_k X_q^k(p)$, then $\mathcal{P}_{\mathcal{F}^{[q]}}$ is the polynomial (in X) defined by $\mathcal{P}_{\mathcal{F}^{[q]}}(X) = \sum \alpha_k X^k$. We have the following result.

Second Recursive Formula. Let $\mathcal{F}^{[q]}$ be any extremal face of $\mathcal{F}^{[k]}$. Then

$$\mathcal{P}_{\mathcal{F}^{[q]}}(X) = \sum_{\substack{\mathcal{F}^{[r]} \in T_{\mathcal{F}^{[q]}} \\ r < q}} (X-1)^{q-r-1} (\mathcal{P}_{\mathcal{F}^{[r]}}(X)) \quad (5.6)$$

A proof of this formula is derived from the first recursive formula in Appendix A.2.

Before going on, we note that the definition of $\mathcal{P}_{\{s_0\}}$ is ambiguous. Indeed, $P_{\{s_0\}} = 1 = \binom{p}{0}$. But we could as well write $P_{\{s_0\}}(p) = \binom{p+k}{0} = X_0^k(p)$ for any k , since the result would anyway be 1. Yet, for a one-dimensional extremal face, we know that $P_{\mathcal{F}^{[1]}}(p) = \binom{p+1}{1} = X_1(p)$, so that $\mathcal{P}_{\mathcal{F}^{[1]}} = X$. The coherence of the second recursive formula implies that

$$\mathcal{P}_{\{s_0\}}(X) = X \quad (5.7)$$

Example. Let us try and apply this formula to the example of Section 5.2: we can write successively

$$\mathcal{P}_6(X) = \mathcal{P}_{\{s_0\}}(X) = X$$

$$\mathcal{P}_5(X) = X$$

$$\mathcal{P}_4(X) = \mathcal{P}_3(X) = X + (X-1)X = X^2$$

$$\mathcal{P}_2(X) = 2X^2 + (X-1)X + (X-1)^2X = X^3 + X^2$$

$$\mathcal{P}_1(X) = (X^3 + X^2) + 2(X-1)X^2 + (X-1)^2X + (X-1)^3X = X^4 + X^3$$

so that $P_{\mathcal{F}^{[k]}}(p) = \binom{p+4}{4} + \binom{p+3}{4}$; $a_0 = 1$ and $a_1 = 1$.

5.3.2. Modified Inclusion Matrix. In order to express the second recursive formula in matrix terms, we now need to define a *modified inclusion matrix*.

Modified Inclusion Matrix. The *modified inclusion matrix* is the $N \times N$ matrix of *strict inclusion* (that is, the matrix \mathcal{M} with $a_{ii} = 0$ instead of 1) in which the last term a_{NN} is replaced by $(X - 1)$. It will be denoted by $\tilde{\mathcal{M}}(X)$ or $\tilde{\mathcal{M}}$.

In the above example (i.e., the example of Section 5.2), we get

$$\tilde{\mathcal{M}} = \begin{pmatrix} 0 & 1 & 1 & 1 & 1 & 1 \\ 0 & 0 & 1 & 1 & 1 & 1 \\ 0 & 0 & 0 & 0 & 1 & 1 \\ 0 & 0 & 0 & 0 & 1 & 1 \\ 0 & 0 & 0 & 0 & 0 & 1 \\ 0 & 0 & 0 & 0 & 0 & X-1 \end{pmatrix}$$

Matrix Formula. $\mathcal{P}_{\mathcal{F}^{[k]}}(X)$ is X times the coefficient $(1, N)$ of $[\tilde{\mathcal{M}}(X)]^k$.

To understand this, one must look at the second recursive formula for any extremal face $\mathcal{F}^{[q]}$: if, recursively, one replaces again $\mathcal{P}_{\mathcal{F}^{[r]}}$ by its expression in terms of the $\mathcal{P}_{\mathcal{F}^{[s]}}$, where $\mathcal{F}^{[s]}$ is a strict extremal face of $\mathcal{F}^{[r]}$, one gets

$$\sum_{\substack{\mathcal{F}^{[q]} \subset \mathcal{F}^{[r]} \subset \mathcal{F}^{[s]} \\ s < r < q}} (X - 1)^{q - s - 2} \mathcal{P}_{\mathcal{F}^{[s]}}$$

Now $s < r < q$ implies $s \leq q - 2$. So we understand that if we go on iterating this process, we will have a sum over *chains of strict inclusion* that will necessarily end up with $\{S_0\}$, that is, $\{S_0\} \subset \mathcal{F}^{[r]} \subset \dots \subset \mathcal{F}^{[s]} \subset \mathcal{F}^{[r]} \subset \mathcal{F}^{[q]}$, with $0 < r < \dots < s < r < q$. And the sum is over *all* those chains of strict inclusion that begin with $\{S_0\}$ and end with $\mathcal{F}^{[q]}$. Moreover, the coefficient in front of $\mathcal{P}_{\{S_0\}}$ is $(X - 1)^{q - \dim\{S_0\} - l} = (X - 1)^{q - l}$, where l is the length of the inclusion chain (which is the number of extremal faces in it but one). Now we can consider that this inclusion chain is a chain of length q if we add to its beginning $q - l$ times $\{S_0\}$:

$$\{S_0\} \subset \dots \subset \{S_0\} \subset \mathcal{F}^{[r]} \subset \dots \subset \mathcal{F}^{[s]} \subset \mathcal{F}^{[r]} \subset \mathcal{F}^{[q]}$$

And if we give a weight to each inclusion, that is, a weight 1 for each strict inclusion and a weight $(X-1)$ for the only nonstrict inclusion allowed, $\{S_0\} \subset \{S_0\}$, the weight of the whole chain, that is, the product of the elementary weights, is exactly $(X-1)^{q-1}$.

Hence, $\mathcal{P}_{\mathcal{F}^{[q]}}$ is $X (= \mathcal{P}_{\{S_0\}})$ time the sum of the weights of all the inclusion chains of length q and that begin with $\{S_0\}$ and end with $\mathcal{F}^{[q]}$. As for $\mathcal{P}_{\mathcal{F}^{[K]}}$, we have of course the same result with chains of length K . And it is a known result in combinatoric analysis (see, for example, ref. 31) that this quantity is given by the coefficient $(1, N)$ of the K th power of the *weighted* (i.e., “modified” here) inclusion matrix $\tilde{M}(X)$.

5.4. Interpretation in Terms of q -Dimensional Simplices

Our purpose in this subsection is to write the polynomial $P_{\mathcal{F}^{[K]}}$ as a sum of elementary polynomials and to interpret each elementary polynomial as the number of integral points inside a normal simplex (of variable dimensionality). More precisely, these simplices are proved to arise from a canonic decomposition of the convex polytope $\mathcal{F}^{[K]}$. Note that this interpretation is related to a first kind of additive binomial formula, since every elementary polynomial is a binomial coefficient.

First of all,

$$X_K(X_K - 1)^{K-q}(p) = \binom{p+1}{q}$$

To prove it, we can for instance use:

$$\sum_{k=0}^{K-q} (-1)^{(K-q)-k} \binom{K-q}{k} \binom{(p+1)+k}{K} = \binom{p+1}{q}$$

Now $\binom{p+1}{q}$ is the number of integral points in a q -dimensional normal simplex of side $p+1-q$. Therefore the polynomial $P_{\mathcal{F}^{[K]}}$ is a sum of elementary polynomials that are the number of integral points in simplices of variable dimensionalities. It is therefore natural to check whether these simplices should arise from a decomposition of the convex polytope $\mathcal{F}^{[K]}$ into simplices of varying dimensionalities.

In addition, in the proof of the matrix formula, we considered strict inclusion chains of extremal faces, and for each such chain, we added a polynomial $X_K(X_K - 1)^{K-q}(p)$, that is, as emphasized just above, the number of integral points in a simplex. Now recall Section 4.2 and the morphism Φ . By this morphism, such an inclusion chain becomes a set of increasing sequence of vertices of the convex polytope. Moreover, the first

and the last faces in a chain are $\{S_0\}$ and $\mathcal{F}^{[K]}$, which correspond, respectively, to S_0 and O . Hence the image of an inclusion chain by Φ exactly defines a normal simplex containing S_0 and O .

Hence the polynomial $P_{\mathcal{F}^{[K]}}$ is a sum of elementary polynomials that are directly related to the numbers of integral points in simplices which are included in the convex polytope $\mathcal{F}^{[K]}$. The complete proof is given in Appendix A.3.2.

Note here the fundamental role played by the one-to-one correspondence, established by Φ , between the extremal faces and the vertices of $\mathcal{F}^{[K]}$: the matrix formula writes the number of configurations as a sum of binomial coefficients. These coefficients can be labeled by inclusion chains, which, through the mapping Φ , are also simplices, and more than "labeled" by these simplices, these binomial coefficients turn out to be precisely the integral volumes of these simplices.

Now that we have decomposed the convex polytope into simplices, we can also interpret the polynomial when it is written in terms of X and not $(X-1)$. Note that X^k is in fact $X_K^k(p)$, which is itself the polynomial $\binom{p+k}{k}$. And this quantity is the number of points in a K -dimensional normal simplex. We are therefore tempted to decompose the convex polytope as a set of such disjoint simplices of the same dimensionality.

5.5. Decomposition into K -Dimensional Normal Simplices

We have just seen in the previous section that the convex polytope of any partition problem can be decomposed into normal simplices of various dimensionalities. The goal of this part is to get a decomposition into simplices of the *same* dimensionalities.

The main problem will be that in the decomposition in K -dimensional normal simplices there are interfaces between the simplices, as can be seen in Fig. 10.

The integral points that lie on these interfaces must not be double-counted. Hence, some simplices in the decomposition must have faces suppressed, and we have to define precisely how these faces will be suppressed.

5.5.1. Descents. It can be proved (Appendix A.3.1) that in every case, the K -dimensional convex polytope of a partition problem can be

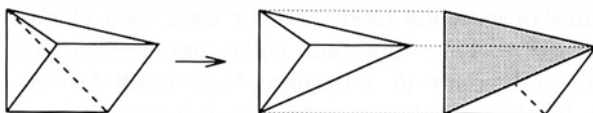

Fig. 10. The gray area is an interface that must not be double-counted.

decomposed into (nondisjoint) K -dimensional normal simplices. This is called a *normal decomposition*:

$$\mathcal{F}^{[K]} = \bigcup_{\substack{O_{\mathcal{F}^{[K]}} < A_{i_1} = A_{i_2} < \dots < A_{i_{K-1}} < S_0 \\ A_j \in V_{\mathcal{F}^{[K]}}} } \text{Simp}(O_{\mathcal{F}^{[K]}}, A_{i_1}, A_{i_2}, \dots, A_{i_{K-1}}, S_0) \quad (5.8)$$

Figure 11 provides an example.

In order to decide how to suppress the interfaces, we have to define the *number of descents* of a simplex: if $\mathcal{S} = \text{Simp}(A_0, A_1, \dots, A_K)$ ($A_0 = O$ and $A_K = S_0$) is a normal simplex of a normal decomposition, let \mathbf{e}_k denote the vector of the Euclidean space parallel to $A_k A_{k+1}$. Now, in the sequence $(i_0, i_1, \dots, i_{K-1})$, let $n(\mathcal{S})$ be the number of indices such that $i_k > i_{k+1}$ (the number of “descents” of this simplex), and let $\nu(k)$ denote the number of simplices of the normal decomposition such that $n(\mathcal{S}) = k$.

In the example of Fig. 11, there are three normal simplices, $\text{Simp}(O, D, E, S_0)$, $\text{Simp}(O, A, B, S_0)$, and $\text{Simp}(O, D, B, S_0)$. The three corresponding sequences of indices are, respectively, $(1, 2, 3)$, $(3, 1, 2)$, and $(1, 3, 2)$, and the numbers of descents are, respectively, 0, 1, and 1. Then $\nu(0) = 1$ and $\nu(1) = 2$.

5.5.2. Descent Theorem and Additive Formulas. Given this definition, we are able to prove (Appendix A.3.1) that, *if there exists a zero-descent simplex in the decomposition*, a way of keeping track of double-counting problems is to remove j interfaces from every j -descent simplex.

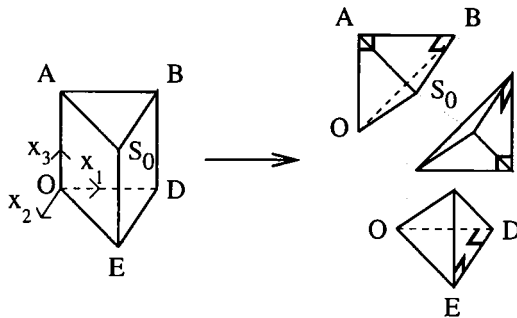

Fig. 11. A simple example with $K=3$: $p \geq x_1 \geq x_2 \geq 0$ and $p \geq x_3 \geq 0$ (x_3 is “free”). The convex polytope obtained is the union of three normal simplices. Note: this is not a standard partition problem, and especially it is not related to a standard tiling problem, but it provides a simple nontrivial example of decomposition in 3D space.

In this proof, we also learn that if we remove j faces from a K -dimensional simplex, its integral volume becomes $\binom{p+K-j}{K}$.

Now we can write the following theorem:

Descent Theorem. With the above notations,

$$P_{\mathcal{F}(K)}(p) = \sum_{j \geq 0} v(j) \binom{p+K-j}{K} \tag{5.9}$$

The proof is now straightforward: there are $v(j)$ simplices that have j interfaces suppressed, and their integral volume is then $\binom{p+K-j}{K}$. ■

Equation (5.9) is the general form of the second kind of *additive* formulas.

These descents were originally used by MacMahon⁽²¹⁾ in a combinatorial context, whereas here they are given a geometrical meaning in terms of normal simplex decomposition.

Remark. If we recall now Section 4.1, we see that Eq. (5.9) has the general form we had given if $a_j = v(j)$. We shall now use this notation a_j instead of $v(j)$.

Remark. $a_j = 0$ when $j < 0$. Moreover, there is only one permutation of the set $\{1, 2, \dots, K\}$ with 0 descent; thus $a_0 = 1$.

5.5.3. Walks and Descents in the Graph T . In the previous normal decomposition, the K -dimensional simplices can be seen as *walks* in the graph T , going from the origin O to S_0 . Indeed, any sequence $O_{\mathcal{F}(K)} < A_{i_1} < A_{i_2} < \dots < A_{i_{K-1}} < S_0$ can be seen as such a walk, since it is a sequence of neighboring points of increasing weight.

Moreover, we have seen (Section 4.3) that the structure of the graph of a partition problem is closely related to the structure of the convex polytope of a lesser dimension partition problem.

These two properties can be combined to get the following: “The total number of simplices ($\sum a_j$) in the decomposition of the convex polytope of a $d + 1 \rightarrow d$ partition problem is the number of walks in the convex polytope of the associated $d \rightarrow d - 1$ partition problem between the extremal points O and S_0 .”

We can now wonder whether the notion of descents is directly readable on these latter walks. If the variable indices of the codimension-one problem are chosen appropriately, the answer is yes.

Indeed, let us suppose that these indices are compatible with the lexicographic³ order upon the coordinates of the partition problem boxes.

³ We recall that given two sequences u_1, u_2, \dots and v_1, v_2, \dots , the first one is said to be greater than the second one according to the lexicographic order if, i_0 being the first index for which $u_{i_0} \neq v_{i_0}$, then $u_{i_0} > v_{i_0}$.

That is, using again the notations of Sections 3.1 and 4.3, the index (i_1, \dots, i_d) is supposed to be greater than the index (i'_1, \dots, i'_d) if it is greater lexicographically.

Suppose that two successive steps $A_{i_k} \rightarrow A_{i_{k+1}} \rightarrow A_{i_{k+2}}$ define a descent in the $d+1 \rightarrow d$ problem. That is, if $A_{i_k} A_{i_{k+1}}$ is parallel to e_{j_k} and $A_{i_{k+1}} A_{i_{k+2}}$ to $e_{j_{k+1}}$, suppose that $j_k > j_{k+1}$. Then, in terms of partitions, the vertices have coordinates

$$A_k \left| \begin{array}{c} \vdots \\ x_{j_{k+1}} = 0 \\ \vdots \\ x_{j_k} = 0 \\ \vdots \end{array} \right. , \quad A_{k+1} \left| \begin{array}{c} \vdots \\ x_{j_{k+1}} = 0 \\ \vdots \\ x_{j_k} = 1 \\ \vdots \end{array} \right. , \quad A_{k+2} \left| \begin{array}{c} \vdots \\ x_{j_{k+1}} = 1 \\ \vdots \\ x_{j_k} = 1 \\ \vdots \end{array} \right.$$

If we use again the notations X_i for the variables in the corresponding $d \rightarrow d-1$ partition problem and if $j_k = (\alpha_1, \dots, \alpha_d)$ and $j_{k+1} = (\beta_1, \dots, \beta_d)$, then

$$A_k \left| \begin{array}{c} \vdots \\ X_{\beta_1, \dots, \beta_{d-1}} = a \\ \vdots \\ X_{\alpha_1, \dots, \alpha_{d-1}} = b \\ \vdots \end{array} \right. , \quad A_{k+1} \left| \begin{array}{c} \vdots \\ X_{\beta_1, \dots, \beta_{d-1}} = a \\ \vdots \\ X_{\alpha_1, \dots, \alpha_{d-1}} = b + 1 \\ \vdots \end{array} \right. , \quad A_{k+2} \left| \begin{array}{c} \vdots \\ X_{\beta_1, \dots, \beta_{d-1}} = a + 1 \\ \vdots \\ X_{\alpha_1, \dots, \alpha_{d-1}} = b + 1 \\ \vdots \end{array} \right.$$

Now, since $(\alpha_1, \dots, \alpha_d) > (\beta_1, \dots, \beta_d)$, either $(\alpha_1, \dots, \alpha_{d-1}) > (\beta_1, \dots, \beta_{d-1})$ or $(\alpha_1, \dots, \alpha_{d-1}) = (\beta_1, \dots, \beta_{d-1})$ and $\alpha_d > \beta_d$. But this last possibility leads to a contradiction, since $(\beta_1, \dots, \beta_d)$ comes after $(\alpha_1, \dots, \alpha_d)$ in the graph. Hence $(\alpha_1, \dots, \alpha_{d-1}) > (\beta_1, \dots, \beta_{d-1})$, and we have a descent in the indices of the variables that are increased by one in the $d \rightarrow d-1$ convex polytope. The converse property is straightforward: if $(\alpha_1, \dots, \alpha_{d-1}) > (\beta_1, \dots, \beta_{d-1})$, then $(\alpha_1, \dots, \alpha_{d-1}, \alpha_d) > (\beta_1, \dots, \beta_{d-1}, \beta_d)$.

5.5.4 Symmetry of the a_j and Maximum Number of Descents.

The following property is given a geometrical proof in Appendix A.4 for any codimension-one partition problem:

Symmetry. There exists an integer M such that for any integer j ,

$$a_j = a_{M-j} \tag{5.10}$$

In codimension one, if we have a $d + 1 \rightarrow d$ partition problem on a $k_1 \times k_2 \times \dots \times k_d$ d -dimensional array, then

$$M = k_1 \cdot k_2 \cdots k_d - (k_1 + \dots + k_d) + d - 1 \tag{5.11}$$

It is worth noticing that the proof we give of this result is deeply related to Ehrhart’s reciprocity law.⁽²⁴⁾

As a consequence, the greater j involved in Eq. (5.9) is M , since $a_0 = 1$ and $a_j = 0$ if $j < 0$. M is the maximum number of descents.

6. COUNTING INTEGRAL POINTS IN THE CONVEX POLYTOPE: MULTIPLICATIVE FORMULAS

We recall here some *multiplicative* formulas, that is, formulas written as a condensed product of the generalized factorial functions originally defined in ref. 10. We first make precise the asymptotic behavior of these functions.

6.1. Generalized Factorial Functions of Order m

6.1.1. Definition. They are defined by induction on m (m integer):

Generalized Factorial Functions.

$$k!^{[0]} = k, \quad k!^{[m]} = \prod_{j=1}^k j!^{[m-1]} \tag{6.1}$$

Note that $k!^{[1]} = k!$.

6.1.2. Properties. When we evaluate entropy, we need to know the asymptotic behavior of $\log k!^{[m]}$ when $k \rightarrow \infty$. We shall now prove that in this limit

$$\log k!^{[m]} = \frac{k^m}{m!} \log k + \alpha_m k^m + O(k^{m-1} \log k) \tag{6.2}$$

where α_m is defined by $\alpha_0 = 0$ and the relation

$$\alpha_{m+1} = \frac{1}{m+1} \left(\alpha_m - \frac{1}{(m+1)!} \right)$$

and where $O(k^{m-1} \log k)$ means a function bounded by $A \cdot (k^{m-1} \log k)$, $A > 0$. Note that for $m = 1$, we recover the two leading terms of the Stirling formula.

The proof will be done by induction on m : the assumption is obvious for $m = 0$. If it is true for a given m , then

$$\begin{aligned} \log k!^{[m+1]} &= \log \prod_{j=1}^k j!^{[m]} \\ &= \sum_{j=1}^k \log j!^{[m]} \\ &= \sum_{j=1}^k \left(\frac{j^m}{m!} \log j + \alpha_m j^m \right) + A_k \end{aligned}$$

where A_k is bounded by $A \cdot \sum_{j=1}^k j^{m-1} \log j$. Hence, $|A_k| \leq B \cdot (k^m \log k)$ and

$$\log k!^{[m+1]} = \sum_{j=1}^k \left(\frac{j^m}{m!} \log j + \alpha_m j^m \right) + O(k^m \log k)$$

Now, this last sum is almost an integral:

$$\sum_{j=1}^k \frac{j^m}{m!} \log j + \alpha_m j^m = \int_1^{k+1} \left(\frac{x^m}{m!} \log x + \alpha_m x^m \right) dx + b_k$$

Since the integrand is an increasing function for x greater than a real c_m ,

$$\begin{aligned} b_{c_m} \leq b_k &\leq \sum_{j=c_m}^k \left(\frac{(j+1)^m}{m!} \log(j+1) + \alpha_m (j+1)^m - \frac{j^m}{m!} \log j - \alpha_m j^m \right) + b_{c_m} \\ &\leq \frac{(k+1)^m}{m!} \log(k+1) + \alpha_m (k+1)^m + b_{c_m} \\ &= O(k^m \log k) \end{aligned}$$

Moreover,

$$\int_1^{k+1} \left(\frac{x^m}{m!} \log x + \alpha_m x^m \right) dx = \frac{k^{m+1}}{(m+1)!} \log k + \alpha_{m+1} k^{m+1} + O(k^m \log k)$$

where

$$\alpha_{m+1} = \frac{1}{m+1} \left(\alpha_m - \frac{1}{(m+1)!} \right)$$

Hence,

$$\log k!^{[m+1]} = \frac{k^{m+1}}{(m+1)!} \log k + \alpha_{m+1} k^{m+1} + O(k^m \log k)$$

We know the existence of a relation between the usual factorial function and an analytic function, the Γ function. Similarly, one may wonder whether continuous functions can be defined which meet the generalized factorials at integral points. Such a function is already known for the second-order factorial function: the so-called ‘‘Barnes function.’’⁽²⁸⁾ The generalization to higher orders is indeed possible along the same lines.

6.2. Exact and Approximate Multiplicative Formulas

The term $W_{k_1, k_2, \dots, k_d, p}^{d+1-d}$ still denotes the number of partitions of height p on a $k_1 \times k_2 \times \dots \times k_d$ hypercubic lattice (or the number of corresponding tilings).

We then have the following exact results:

- $2 \rightarrow 1$ partitions:

$$W_{k,p}^{2-1} = \binom{k+p}{k} = \frac{(k+p)!}{k! p!}$$

- $3 \rightarrow 2$ partitions:

$$W_{k,l,p}^{3-2} = \frac{(k+l+p-1)!^{[2]}(k-1)!^{[2]}(l-1)!^{[2]}(p-1)!^{[2]}}{(k+p-1)!^{[2]}(l+p-1)!^{[2]}(k+l-1)!^{[2]}}$$

The first formula is trivial. The second comes from a work of MacMahon.⁽²¹⁾ It is rewritten here in terms of generalized factorials. It is in fact derived from the generating function:

$$\sum_{\pi} q^{n(\pi)} = \frac{H(k+l+p) H(k) H(l) H(p)}{H(k+l) H(k+p) H(l+p)} \tag{6.3}$$

where the sum runs over all plane partitions π counted by $W_{k,l,p}^{3 \rightarrow 2}$, where $w(\pi)$ is the sum of the parts of the partition $[w(\pi) = x_1 + \dots + x_k]$ and

$$H(n) = [n-1]!_q [n-2]!_q \dots [2]!_q [1]!_q \tag{6.4}$$

where $[n]!_q = [n]_q [n-1]_q \dots [2]_q [1]_q$ and $[n]_q = 1 + q + q^2 + \dots + q^{n-1}$. When $q=1$, we get the above formula for $W^{3 \rightarrow 2}$. Note that we have a proof of this formula (for $q=1$) directly derived from the Gessel–Viennot method^(25,26) (the idea is to consider a partition as the family of paths that separate regions where the parts are equal, and then to compute the determinant given by the Gessel–Viennot method).

As for the $4 \rightarrow 3$ partitions, there is a generalization written with factorial functions of order 3. It is known to be only an approximate formula⁽¹⁰⁾:

$$\bullet W_{k_1, k_2, k_3, k_4}^{4 \rightarrow 3} \simeq \frac{(k_1 + k_2 + k_3 + k_4 - 2)!^{[3]} \prod_{i < j} (k_i + k_j - 2)!^{[3]}}{\prod_{i < j < l} (k_i + k_j + k_l - 2)!^{[3]} \prod_i (k_i - 2)!^{[3]}}$$

We shall discuss later the validity of this $4 \rightarrow 3$ result. A set of multiplicative approximate formulas can similarly be proposed for all codimension-one problems:

$$\bullet W_{k_1, \dots, k_{n+1}}^{n+1 \rightarrow n} \simeq \frac{\prod_{j=1}^{n+1} j - n \equiv 1[2] \prod_{i_1 < i_2 < \dots < i_j} (k_{i_1} + k_{i_2} + \dots + k_{i_j} - n + 1)!^{[n]}}{\prod_{j=1}^{n+1} j - n \equiv 0[2] \prod_{i_1 < i_2 < \dots < i_j} (k_{i_1} + k_{i_2} + \dots + k_{i_j} - n + 1)!^{[n]}}$$

Note that these approximate functions are built so that they obey two important constraints: they are invariant under permutations of the k_i and they reduce to the equivalent formula for one dimension less when one k_i equals unity.

7. CONFIGURATION ENTROPY

By definition, the configurational entropy per tile is

$$S = \log(\# \text{ configurations}) / \# \text{ tiles} \tag{7.1}$$

We are mainly interested in the configurational entropy per tile at the infinite-size limit: $S^{D \rightarrow d}$ is the limit of $\log(\# \text{ configurations}) / \# \text{ tiles}$ when the boundary goes uniformly to infinity, with given ratios between the k_j . The results given by our analysis concern tilings associated with standard partitions, which imply a specific type of fixed boundary conditions, containing an intrinsic phason strain, as opposed to the free or periodic boundary conditions: the present boundary conditions will be simply

denoted as *fixed* in the following. In Section 7.3, more complex “phason-free” fixed boundary conditions will be briefly discussed.

7.1. Fixed Boundary Entropy

We can easily calculate S^{2-1}

$$S^{2-1} = -x_1 \log x_1 - x_2 \log x_2 \tag{7.2}$$

where $x_i = k_i / (k_1 + k_2)$. The S^{3-2} has been derived by Elser⁽⁷⁾; it is a direct consequence of the formula of Section 6.2:

$$S^{3-2} = \frac{\sum_{i=1}^3 x_i^2 \log x_i - (1 - x_i)^2 \log(1 - x_i)}{2X} \tag{7.3}$$

where $x_i = k_i / (k_1 + k_2 + k_3)$ ($k_3 = p$) and $X = x_1 x_2 + x_1 x_3 + x_2 x_3$.

From the approximate formula of Section 6.2, we get an entropy formula which was proposed⁽¹⁰⁾ as an Ansatz for the exact entropy:

$$S^{4-3} = \left[- \sum_{i=1}^4 x_i^3 \log x_i + \sum_{\langle i,j \rangle} (x_i + x_j)^3 \log(x_i + x_j) - \sum_{i=1}^4 (1 - x_i)^3 \log(1 - x_i) \right] / 6X \tag{7.4}$$

where

$$x_i = \frac{k_i}{k_1 + k_2 + k_3 + k_4} \quad (k_4 = p)$$

$$X = x_1 x_2 x_3 + x_1 x_2 x_4 + x_1 x_3 x_4 + x_2 x_3 x_4$$

Similar formulas can be derived for all codimension-one entropies. Note that these entropies are maximal in the diagonal cases $x_i = 1 / (d + 1)$, and that they have a quadratic behavior near this maximum (see below).

Our new geometrical analysis in terms of normal simplices enumeration enables us to add new exact enumeration values and their associated entropies.

Before going on, we briefly discuss the algorithm used to make this new enumeration. It uses the Descent Theorem. But it is also closely related to the existence of the graph associated with the partition problem and to its simple structure (convex polytope of a $3 \rightarrow 2$ problem). The idea is

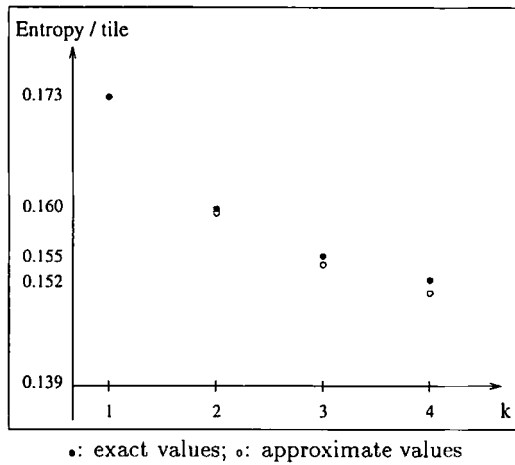

Fig. 12. Values of the entropy per tile of the diagonal $4 \rightarrow 3$ case $[\log(W_{k,k,k,k}^{4 \rightarrow 3}) / \# \text{ tiles}]$. The exact values are calculated thanks to an algorithm derived from this analysis, whereas the approximate values come from the formula of Section 7.1; 0.139 is the expected infinite-size limit of this entropy.

simply to attach a vector to each vertex of the graph, the vector of the partial a_j 's. For a given j , the partial a_j of a vertex is the number of walks in the graph that go from the origin to this vertex and that have j descents. Then we compute recursively the partial a_j 's of the vertices of increasing weight. For a given vertex, they only depend on the vertices that are one two levels above in the graph.

The accessible values, which are several order of magnitude larger than the values obtained by previous methods, where the partitions were enumerated one by one, would be out of reach by a brute-force algorithm. They correspond to tilings of larger sizes ($\approx 200\text{--}300$ tiles). Table II gives some values and their corresponding entropy. The diagonal values for entropy are plotted in Fig. 12.

Table II. Entropy per Tile in Some $4 \rightarrow 3$ Cases

Number of tilings	Entropy	No. of tiles
$W_{2,2,2,2}^{4 \rightarrow 3} = 168$	0.160	32
$W_{3,3,3,3}^{4 \rightarrow 3} = 17\,792\,748$	0.155	108
$W_{4,4,4,2}^{4 \rightarrow 3} = 6\,188\,212\,000$	0.141	160
$W_{4,4,4,3}^{4 \rightarrow 3} = 37\,269\,304\,282\,344$	0.150	208
$W_{4,4,4,4}^{4 \rightarrow 3} = 75\,241\,806\,496\,951\,632$	0.152	256
$W_{4,4,4,5}^{4 \rightarrow 3} = 65\,412\,153\,848\,662\,653\,220$	0.150	304

Table III. Phason Elastic Constants of the $d+1 \rightarrow d$ Problem^a

d	σ_0	σ_2	K
1	$\log 2$	$-1/2$	$1/2$
2	$3/2 \log 3 - 2 \log 2 \simeq 0.261$	$9/4 \log 3 - 9/2 \log 2 \simeq -0.669$	$-3/2 \log 3 + 3 \log 2 \simeq 0.431$
3	$22/3 \log 2 - 9/2 \log 3 \simeq 0.139$	$-24 \log 3 + 112/3 \log 2 \simeq -0.489$	$6 \log 3 - 28/3 \log 2 \simeq 0.122$

^a The expressions for $d > 3$ can also be derived.

Note that although the calculated entropy for the (4,4,4,4) case goes toward the value given by the above Ansatz in the diagonal case, it nevertheless cannot be taken as a confirmation of this Ansatz.

7.2. Fixed-Boundary Phason Elastic Constants

The phason elastic constants⁽⁸⁾ are calculated here for codimension-one partition problems. We use the exact results for $d=1$ or $d=2$, and the approximate results for greater dimensions. The entropy is maximal for the diagonal x_i : $x_i^{(0)} = 1/(d+1)$. We develop the entropy near this maximum entropy point,

$$S^{(d+1 \rightarrow d)}(x^{(0)} + dx) = \sigma_0 + \sigma_2(dx)^2 + \dots \quad (7.5)$$

where $\sum dx_i = 0$.

The numerical coefficients σ_i are given in Table III. However, the usual definition for elastic constants K is given in terms of phason strain E defined, for example, in ref. 8: $S = \sigma_0 - \frac{1}{2}KE^2 + \dots$. One needs some algebra to express our elastic constants in this system of variables. For instance, the $3 \rightarrow 2$ constant is $K = -3/2 \log 3 + 3 \log 2 \simeq 0.43$ [whereas it is equal to $2(\sqrt{3}/2) \pi/9 \simeq 0.60$ for the periodic boundary entropy per tile^{(17,8),4}]. For the $4 \rightarrow 3$ problem, we find similarly $K = 6 \log 3 - (28/3) \log 2 \simeq 0.12$.

7.3. Entropy and Boundary Conditions

As mentioned above, the entropies we get here (and therefore the phason elastic constants) are specific to the fixed boundary condition. Indeed, the partition viewpoint implies that those tilings which we enumerate are inscribed in a polygon (or a polyhedron), the shape of which is a strong constraint: fixed ratios for the occurrence of the different types of tiles

⁴ One must be careful here with the length scales, both in the parallel space and in the perpendicular space.

correspond to a given boundary condition, and these tilings of rhombi (or rhombohedra) have this property that the order imposed by the boundary penetrates deeply into the tiling bulk.⁽⁷⁾ Consequently, the entropy itself depends on this boundary condition: for given ratios of the different tiles (a given phason strain⁽⁸⁾), the free (or periodic) boundary entropy can be several percent higher than the fixed-boundary one. This can be illustrated by the only tiling type which has been completely solved for both fixed and free boundary conditions: the $3 \rightarrow 2$ case. The fixed-boundary diagonal entropy per tile is 0.261, whereas the free one is 0.323⁽¹⁶⁾ (the latter value refers to the ground-state entropy of the antiferromagnetic Ising model on a triangular lattice; and there is a one-to-one correspondence between this model ground states and the free-boundary $3 \rightarrow 2$ tilings).

More precisely, this dependence of the entropy on the boundary condition can be related to the existence, in the fixed-boundary case, of a phason gradient in the neighborhood of the boundary. The next subsection is devoted to this point.

Before going on, let us point out that the boundary conditions of the partition problems can be generalized in such a way as to produce phason-free *fixed*-boundary tilings. For example, in the $3 \rightarrow 2$ case, this amounts to shifting from a rectangular to a hexagonal array and to modifying condition (3.2). In terms of tilings, this leads to staircase-shaped boundaries, which then have a negligible influence toward the bulk. We have numerically verified that the corresponding entropy matches the free-boundary value. But the price to pay is that we have not been able yet to apply to these partition problems the generalized framework developed throughout this paper.

7.4. Link Between Free- and Fixed-Boundary Entropies

First of all, let us state that the following analysis is not restricted to codimension-one tilings. The following calculations are deeply related to *coarse graining* arguments.⁽⁸⁾ We shall also use the membrane representation of tilings: a $D \rightarrow d$ tiling can be seen as a d -dimensional membrane in a D -dimensional space attached to a given *frame*. For instance, for a $3 \rightarrow 2$ tiling, this frame is a (nonflat) 3-dimensional hexagon (see Section 2.5). Moreover, we shall make the essential distinction between *faceted* membranes and *smooth* membranes.

- A faceted membrane is the exact representation of a tiling, with well-defined facets.
- A smooth membrane does not represent one particular tiling, but a class of tilings, as discussed below.

In addition, all the membranes will be analytically represented by the equation $z_j = \phi_j(y_i)$, where the y_i are Euclidean coordinates on the d -dimensional Euclidean subspace on which the tilings are mapped, and the z_j are $D - d$ complementary coordinates. The function ϕ is defined on a polygonal domain Δ , the boundary of which has the same shape as the usual polygonal boundary of tilings, but not necessarily the same size. Indeed, the side lengths of Δ are the ratios $x_i = k_i / \sum k_j$. The values of the function ϕ on the boundary $\partial\Delta$ of Δ are fixed so that the set $\phi(\partial\Delta)$ represents the frame of the membranes. The fact that the membranes are directed ensures that ϕ is always a single-valued function. In this viewpoint, the phason strain E of the membranes is given by $\nabla\phi$. The set of functions ϕ associated with smooth membranes is denoted by F . For any number of tiles N , all the membranes are "rescaled" so that they are bounded by the above frame (that is, we choose to keep constant the sides of the domain Δ , while the tile sizes go to zero when N goes to infinity).

Now, let a given smooth membrane be represented by the function ϕ . We call $s[\phi]$ the entropy per tile associated with this membrane, which is defined as follows:

$$s[\phi] = \lim_{N \rightarrow \infty} \frac{\log(\# N\text{-tile faceted membranes close to } \phi)}{N} \quad (7.6)$$

We shall not discuss here the meaning of *close*. The interested reader can refer to the discussion by Henley,⁽⁸⁾ and especially Section (6.1), "Coarse Graining."

As a result,

$$s[\phi] = \frac{\int_{\Delta} dy^d \sigma(\nabla\phi)}{V(\Delta)} \quad (7.7)$$

where σ is the *free*-boundary entropy per tile associated with a given phason strain [the integral is divided by $V(\Delta)$, the d -dimensional volume of Δ , in order to get an entropy per tile]. In fact, we have smoothed the faceted membranes by integrating in $s[\phi]$ the short-wavelength fluctuations of the faceted membranes.⁽⁸⁾

Consider now the class of fixed-boundary tilings with N tiles, $N \gg 1$, the ratios of different tiles being fixed by the x_j . Then, the number of such tilings close to a membrane m defined by ϕ is $e^{Ns[\phi]}$. The total number of tilings in this class is then

$$\# \text{ tilings} = \int_{\phi \in F} e^{Ns[\phi]} \mathcal{D}\phi \quad (7.8)$$

where $\mathcal{D}\phi$ is a functional measure containing the information relative to the above-mentioned “closeness.”

Now we suppose that there exists a unique function ϕ_{\max} on which s is maximum and that, near ϕ_{\max} , $s[\phi]$ has a quadratic behavior:

$$s[\phi] = s[\phi_{\max}] - \int_A d^d u \int_A d^d v k(u, v) [\phi(u) - \phi_{\max}(u)] [\phi(v) - \phi_{\max}(v)] + \dots \tag{7.9}$$

where k is a positive quadratic form.

Combining the above two equations and using a generalized saddle-point argument (the space of functions is infinite dimensional) and the calculation of a generalized Gaussian integral, we find for the fixed boundary entropy per tile $S(x_i)$

$$S(x_i) = \lim_{N \rightarrow \infty} \frac{\log(\# \text{ tilings})}{N} \tag{7.10}$$

$$= s[\phi_{\max}] \tag{7.11}$$

independent of the nature of $\mathcal{D}\phi$. Hence, the fixed-boundary entropy is given by the maximum of a functional s using *free*-boundary functions.

Intuitively, this result can be explained by saying that the fixed-boundary number of faceted membranes is dominated by the number of faceted membranes close to a smooth membrane maximizing the functional s . Since this membranes close to ϕ_{\max} are entropically dominant, the equilibrium state of this statistical mechanics problem is precisely ϕ_{\max} , and, owing to the boundary frame constraints, this latter membrane presents a phason gradient from the boundary to the very center of Δ . It is only near this center that the membrane is free, or, in other words, that its phason strain is equal to the free-boundary one. This viewpoint also clarifies in which sense the order imposed by the boundary penetrates into the bulk.

Example. The simplest nontrivial example is again the $3 \rightarrow 2$ tiling problem. As described in Fig. 13, the domain Δ is hexagonal and the corresponding frame is a nonflat hexagon in the 3-dimensional space.

In principle, the knowledge of the function σ enables us, for given ratios x_i , to derive the fixed-boundary entropy. Theoretically, we are therefore able to derive the fixed-boundary maximum entropy σ_0^{fixed} and elastic constant K^{fixed} from their corresponding free boundary values σ_0^{free} and K^{free} and to invert these relations. Indeed, in the quadratic approximation

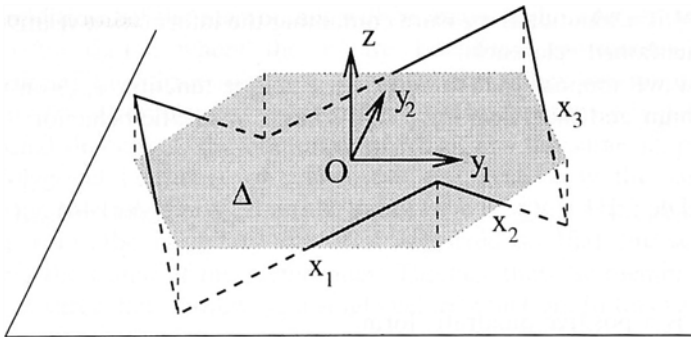

Fig. 13. In the 3 → 2 problems, the functions ϕ are defined on a hexagonal domain \mathcal{A} of sides $x_1, x_2,$ and x_3 . Their values on the boundary $\partial\mathcal{A}$ are fixed so that the membranes are attached to the nonflat hexagonal frame composed of six adjacent edges of the rectangular parallelepiped.

$\sigma = \sigma_0^{\text{free}} - \frac{1}{2}K^{\text{free}}(\nabla\phi)^2$ and the maximization of $s[\phi]$ on F is equivalent to the minimization of

$$t[\phi] = \frac{\int_{\mathcal{A}} dy^d (\nabla\phi)^2}{V(\mathcal{A})}$$

This functional is easily minimized numerically. Figure 14 shows the representation of the 3 → 2 function minimizing $t[\phi]$.

Remark. The solution of the minimization of $t[\phi]$ (or, in the quadratic approximation, the maximization of $s[\phi]$) is given by $\partial s[\phi]/\partial\phi = 0$, where $\partial s[\phi]/\partial\phi$ is the functional derivative of $s[\phi]$. This last equation

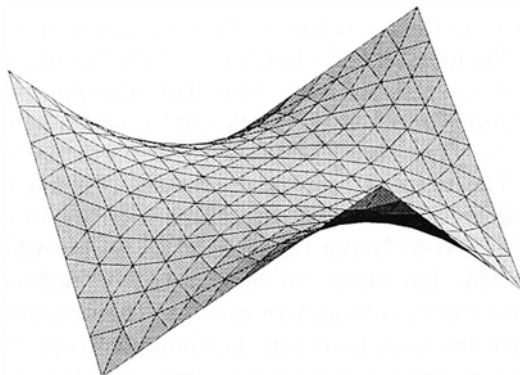

Fig. 14. The 3 → 2 membrane minimizing $t[\phi]$ (quadratic approximation).

implies $\Delta\phi = 0$. It must be solved with the boundary condition imposed by the frame. Hence, since $\Delta\phi = 0$ is the equation of a minimum surface in the approximation of small gradients, the present problem is related to finding minimal surfaces attached to a fixed frame.

The above considerations relate completely the fixed- and free-boundary problems. Of course, the precision of the so-obtained numerical values depends greatly on the validity of the quadratic approximation used so far. Unfortunately, this validity is limited to small gradient domains, and near the boundary this approximation is therefore incorrect. To obtain more precise results, we would then need to know exactly the entropy per tile for any phason gradient. For example, for the $3 \rightarrow 2$ entropy, this would require the tedious numerical calculation of many integrals.⁽¹⁷⁾

Nevertheless, the entropy per tile for the fixed-boundary entropy obtained in this quadratic approximation is 0.253, whereas the expected result is 0.261: this approximation is therefore reasonable.

So the situation is as follows: the random tilings generated by partitions provide a well-defined statistical physics problem. For a fixed shape of the boundary, the entropy tends to a well-defined limit as the tiling size increases. But the entropy density is not uniform in the tilings and increases from the surface to the bulk.

In what respect is this model suited to describe real physical structures? The partition-generated tilings provide very interesting models having inhomogeneous entropy distributions. Such a lack of homogeneity is expected in several physical situations when the system is subject to specific constraints and specific boundary conditions. In the case of quasicrystals, these materials often grow at interfaces with crystalline parent phases, whose influence would then penetrate the bulk of the quasicrystal (as long as the entropy stabilization mechanism proves to be dominant in this case, a point which is still under debate).

8. CONCLUSIONS

The present analysis enables us to give a geometrical picture of generalized partition problems. It provides additive formulas and, thanks to very simple algorithms, it greatly improves the exact enumeration for finite-size systems. This paper mainly treats any-dimensional codimension-one partition problems, for which an Ansatz for the entropy had been previously proposed. Our new additive formulas enable us to test this conjecture further. However, although we can treat larger sizes than was done before, we cannot give conclusive results for the entropy at the infinite-size limit. Indeed, the dimensionality of the configuration space, and then the complexity of the algorithms, considerably increase with the number of

tiles. Note that the only standard random tiling type (by standard we mean a tiling with rhombi in 2D and rhombohedra in 3D) which has been completely solved so far is the simplest one, obtained by mapping from 3D to 2D, for which an exact configurational entropy multiplicative formula is known. In contrast, exact results also exist for other kinds of tilings, such as the triangle-square tiling.^(18,19)

Nonetheless, all these results, whether exact or approximate, display an important configurational entropy for random tiling models. This entropy also has a quadratic behavior near its maximum, which is a fundamental hypothesis of the random tiling model. However, one must keep in mind that the kind of entropies we compute here are entropies per tile, whereas in more realistic models of quasicrystals the tiles are decorated and the relevant quantities are then the entropies per atom, which are then significantly smaller than the previous ones.

Our numerical results are specific to the fixed-boundary conditions. We have already mentioned that our enumeration method needs a specific fixed boundary. The entropy itself depends on this boundary condition (which fixes the ratios of the different kinds of tiles or, in other words, the *phason strain*⁽⁸⁾), and the free (or periodic) boundary entropy can be higher by several percent than ours. For example, the maximum entropy per tile for the $3 \rightarrow 2$ tilings, which occurs when the three differently oriented rhombi are equally numerous, is equal to 0.323 in the free-boundary case⁽¹⁶⁾ and to 0.261 in the fixed-boundary one. As shown above, this difference can be controlled well by simple arguments. Indeed, although a fixed-boundary tiling has a bulk very close to a free-boundary one, the effect of the boundary penetrates deeply into the tiling in the form of a phason strain gradient between the boundary and the bulk. This gradient is explicitly taken into account (with certain approximation), which allows a qualitative as well as quantitative description of this phenomenon. This enables us to prove that there is only a few percent relative difference between both entropies. In addition, the relative difference between these two entropies seems to decrease with both dimension and codimension.

All the topics concerned by the new tools provided by this work have not been exhaustively tackled yet. Even the codimension-one problems need further treatment. In particular, a first step would be to improve the algorithms to treat larger tilings, in order to validate further the entropy Ansatz. Besides, we would like to have a geometrical interpretation of this Ansatz. Indeed, the structure of the approximate formulas for the codimension-one enumerations makes us think that they could be linked to (approximate) generalizations of the hook formula,⁽³⁴⁾ which is deeply linked to the enumeration of walks in the graphs associated with lower dimensional problems (see Appendix B).

Higher codimension problems can also be analyzed through this geometrical viewpoint, but the configuration space adopts a more complex structure. The iterative partition process induces a nice fibered structure, but convexity as a whole is lost. It is nevertheless possible to develop further tools, and we have already obtained interesting results about the simplex decomposition in these cases, such as a generalized descent theorem and exact enumerations of simplices, which will be published separately.

We have not discussed here some consequences of the knowledge of the configuration space provided by this analysis, in terms of structure, ergodicity, or connectivity. For instance, it gives interesting results concerning the enumeration of transformation paths between different tilings. Here also this analysis will be much richer for higher codimension problems, where the nonconvexity of the configuration space is not only a cause of complexity, but also a source of mathematical richness.

Of course, a complete calculation of the free energy necessarily goes together with the introduction of energy in the tilings, assigning different energy costs to different local configurations of tiles. One needs to add an additional dimension to the configuration space (for the energy) and thus to have access to the energy landscape. This is not an easy task, but we have already given some arguments suggesting a hierarchically structured energy landscape.⁽²⁰⁾ Note that if this appears to be true for the real quasicrystalline structure, one would then expect some glasslike properties in quasicrystals.

APPENDIX A. PROOFS

A.1. Integral Volume of a Normal Simplex

Up to basis vector permutations, there is no loss of generality in supposing that the q -dimensional normal simplex $\mathcal{S}^{[q]}$ of side s is a face of the “standard” simplex $\text{Simp}(A_0 = O, A_1, \dots, A_K = S_0)$, where A_k is the point of coordinates

$$(s, \dots, s, \underbrace{0, \dots, 0}_{k \text{ times}})$$

That is, $\mathcal{S}^{[q]} = \text{Simp}(A_{k_0}, \dots, A_{k_q})$. Let $\mathbf{u}_i = A_{k_i} A_{k_{i-1}}$, V_1 be the affine space defined by the A_{k_i} , and V_2 be the affine space defined by the A_i , $i = 0, \dots, q$. Then

$$f: \begin{cases} O \mapsto A_{k_0} \\ \mathbf{e}_i \mapsto \mathbf{u}_i \end{cases}$$

is a unimodular affine map from V_2 to V_1 . Indeed, if M is an integral point in V_2 , then $f(M)$ is integral; if N is an integral point (of \mathbf{Z}^K) in V_1 , then the resolution of the linear system $f(M) = N$ shows that the unique solution M is an integral point. Therefore f defines a linear bijection between the integral points in V_2 and the integral points (of \mathbf{Z}^K) in V_1 .

In particular, if M_1, \dots, M_n are integral points, then

$$\begin{aligned} &\text{Card}(\text{Simp}(M_1, M_2, \dots, M_n) \cap \mathbf{Z}^K) \\ &= \text{Card}(\text{Simp}(f(M_1), f(M_2), \dots, f(M_n)) \cap \mathbf{Z}^K) \end{aligned}$$

Now, by $f, A_{k_i} \mapsto A_j$. Hence, this problem is equivalent to the enumeration of the configurations in a linear partition problem (Section 3.5):

$$P_{\mathcal{F}^{(q)}}(s) = \text{Card}(\text{Simp}(A_0, \dots, A_q) \cap \mathbf{Z}^K) \tag{A.1}$$

$$= \binom{s+q}{q} \tag{A.2}$$

A.2. Proof of the Second Recursive Formula (Section 5.3.1)

We need to introduce a notation a bit more complex than in Section 5.3.1. Let us write the polynomial $P_{\mathcal{F}^{(q)}}$ in terms of elementary polynomials X_q^k , q' not necessarily equal to q [i.e., in the basis $(X_q^k)_{k \in \mathbf{Z}}$, and not $(X_k^q)_{k \in \mathbf{Z}}$, as in Section 5.3.1]: $P_{\mathcal{F}^{(q)}}(p) = \sum \beta_k X_q^k(p)$. Then $\mathcal{P}_{\mathcal{F}^{(q)'}}$ is the polynomial (in X) defined by $\mathcal{P}_{\mathcal{F}^{(q)'}}(X) = \sum \beta_k X^k$.

The first recursive formula then reads

$$\mathcal{P}_{\mathcal{F}^{(q)'}}(X_q)(p) = \mathcal{P}_{\mathcal{F}^{(q)'}}(X_q)(p-1) + \sum_{\substack{\mathcal{F}^{(q)} \in \mathcal{T}_{\mathcal{F}^{(q)'}} \\ r < q}} P_{\mathcal{F}^{(r)}}(p-1)$$

But since for any P ,

$$\binom{P}{q} - \binom{P-1}{q} = \binom{P-1}{q-1},$$

we get $X_q''(p) - X_q''(p-1) = X_{q-1}''(p-1)$ and $\mathcal{P}_{\mathcal{F}^{(q)'}}(X_q)(p) - \mathcal{P}_{\mathcal{F}^{(q)'}}(X_q)(p-1) = \mathcal{P}_{\mathcal{F}^{(q)'}}(X_{q-1})(p-1)$. So

$$\mathcal{P}_{\mathcal{F}^{(q)'}}(X_{q-1})(p-1) = \sum_{\substack{\mathcal{F}^{(r)} \in \mathcal{T}_{\mathcal{F}^{(q)'}} \\ r < q}} P_{\mathcal{F}^{(r)}}(p-1)$$

and thanks to Eq. (5.4) of Section 5.3.1, $X_r^k = (X_{q-1} - 1)^{q-1-r} X_{q-1}^k$, then

$$P_{\mathcal{F}^{[r]}|}(p-1) = \mathcal{P}_{\mathcal{F}^{[r]}|}(X_r)(p-1) = [(X_{q-1} - 1)^{q-1-r} \mathcal{P}_{\mathcal{F}^{[r]}|}(X_{q-1})](p-1)$$

and then

$$\mathcal{P}_{\mathcal{F}^{[q]}|}(X_{q-1})(p-1) = \sum_{\substack{\mathcal{F}^{[r]} \in \mathcal{T}_{\mathcal{F}^{[q]}} \\ r < q}} [(X_{q-1} - 1)^{q-1-r} \mathcal{P}_{\mathcal{F}^{[r]}|}(X_{q-1})](p-1)$$

We then just have to make the substitution $X_{q-1}(p-1) \rightarrow X$. ▀

A.3. Decompositions: Proofs of Sections 5.4 and 5.5

Here we prove the existence of decompositions into both q -dimensional and K -dimensional simplices. However, since the main result, in algorithmical terms, is the Descent Theorem, we first prove this theorem and the decomposition into K -dimensional simplices. The second proof being quite similar to the first, it will be exposed more rapidly.

A.3.1. Proof of the Descent Theorem (Sections 5.5.1 and 5.5.2). Here we prove the existence of the decomposition of $\mathcal{F}^{[K]}$ into K -dimensional simplices and more precisely the Descent Theorem. The simplices naturally appear in this proof as total orders compatible with the partition problem partial order.

Consider a partition problem defined by the inequalities (3.1) and (3.2) of Section 3.2: $x_i \leq x_j$ and $0 \leq x_i \leq p$.

We suppose the existence of a zero-descent simplex in the decomposition [this means that we suppose that all the partitions which satisfy $p \geq x_1 \geq x_2 \geq \dots \geq x_K \geq 0$ lie in the simplex or, in other words, that the total order $x_1 \geq x_2 \geq \dots \geq x_K$ is compatible with the inequalities (3.1)].

In the K -dimensional configuration space, for each couple of indices $\{i, j\}$, $i < j$, we define two half-spaces:

- $H_{i,j}^+$ is the set of points such that $x_i \geq x_j$.
- $H_{i,j}^-$ is the set of points such that $x_i < x_j$.

Now, given a pair of indices $\{i, j\}$, $i < j$, the inequalities (3.1) of the partition problem may imply that an inequality holds between x_i and x_j for any allowed partition. In this case, we say that i and j are *dependent*. Otherwise we say that they are *independent*. In the example of Section 3.1, 2 and 9 are independent, whereas 2 and 7 are not.

Note that, since we know the existence of a zero-descent simplex, when i and j are dependent ($i < j$), the inequality is necessarily $x_i \geq x_j$

(and not $x_j \geq x_i$). In effect, the zero-descent simplex is defined by $p \geq x_1 \geq x_2 \geq \dots \geq x_K \geq 0$ and if $i < j$, it is contained in the half-space $x_i \geq x_j$ (and not $x_j \geq x_i$). The same inequality holds for the whole convex polytope. As a conclusion, when i and j are dependent ($i < j$), the convex polytope $\mathcal{F}^{[K]}$ is in $H_{i,j}^+$.

We shall now only consider the inequalities (3.1) of the partition problem. Afterward we shall make the intersection with inequalities (3.2). The set of points that satisfy inequalities (3.1) is denoted by Q (so $\mathcal{F}^{[K]} = \{(x_k)/(x_k) \in Q \text{ and } \forall i, 0 \leq x_i \leq p\}$).

Now (dep. = dependent),

$$Q = \bigcap_{i < j \text{ dep.}} H_{i,j}^+$$

We can always define a disjoint partition of \mathbf{R}^K in terms of the $H_{i,j}^+$ sets (ind. = independent):

$$\mathbf{R}^K = \bigcap_{i < j \text{ ind.}} \left(H_{i,j}^+ \cup H_{i,j}^- \right) = \bigcup_{(e_{ij})_{i < j \text{ ind.}} \in \{+, -\}} \left(\bigcap_{i < j \text{ ind.}} H_{i,j}^{e_{ij}} \right)$$

This way of writing \mathbf{R}^K might seem trivial, but its interest and meaning will appear in the following:

$$Q = Q \cap \mathbf{R}^K = \left(\bigcap_{i < j \text{ dep.}} H_{i,j}^+ \right) \cap \left(\bigcup_{(e_{ij})_{i < j \text{ ind.}} \in \{+, -\}} \left(\bigcap_{i < j \text{ ind.}} H_{i,j}^{e_{ij}} \right) \right)$$

So Q is the disjoint union of the different sectors of space defined by a given set of signs $(e_{ij})_{i < j \text{ independent}}$:

$$Q = \bigcup_{(e_{ij})_{i < j \text{ ind.}} \in \{+, -\}} \left[\left(\bigcap_{i < j \text{ ind.}} H_{i,j}^{e_{ij}} \right) \cap \left(\bigcap_{i < j \text{ dep.}} H_{i,j}^+ \right) \right] \tag{A.3}$$

Hence, such a sector is defined by a set of strong ($e_{ij} = -$) or weak ($e_{ij} = +$ or $i < j$ dependent) inequalities.

Now let us consider the order relation among the variables x_i associated with such a set of inequalities: it is a total order, since, given two variables, we can always compare them. Suppose now there is a cycle of length n in this order relation

$$x_{i_1} \rightarrow x_{i_2} \rightarrow \dots \rightarrow x_{i_n} \rightarrow x_{i_1}$$

where \rightarrow means \geq or $>$. But in this sequence of indices, there is necessarily at least one descent ($i_k > i_{k+1}$) and hence a strict inequality ($x_{i_k} > x_{i_{k+1}}$), which denies the existence of such a cycle.

Therefore we have a total order relation with no cycle. It is then of the form

$$x_{i_1} \rightarrow x_{i_2} \rightarrow \dots \rightarrow x_{i_k}$$

If we add now the set of inequalities (3.2), we realize that the convex polytope of the partition problem is a disjoint union of simplices of the form

$$p \geq x_{i_1} \rightarrow x_{i_2} \rightarrow \dots \rightarrow x_{i_k} \geq 0$$

which is what we aimed to prove: indeed, by the definitions of H_+ and H^- , the symbol \rightarrow is a strict inequality only when the two successive indices define a descent. The number of strict inequalities, that is, the number of faces we are to suppress, is therefore equal to the number of descents. We insist here on the fact that if $i_j > i_{j+1}$ and $x_{i_j} = x_{i_{j+1}}$, then the representative point is counted in a simplex where i_j and i_{j+1} are permuted.

Now, given such a simplex, let us use the notation $X_k = x_{i_k}$. Let k_1, \dots, k_v be the indices k which precede the descents (we suppose that there are exactly v descent). Then this simplex is defined by

$$p \geq X_1 \geq \dots \geq X_{k_1} > X_{k_1+1} \geq \dots \geq X_{k_v} > X_{k_v+1} \geq \dots \geq X_K \geq 0$$

The closure of such a simplex is obtained by replacing every strong inequality by a weak one. It is the K -dimensional normal simplex

$$\text{Simp}(O_{\mathcal{F}^{[K]}}, A_{i_1}, A_{i_2}, \dots, A_{i_{k-1}}, S_0)$$

where the A_i are vertices of the graph T of this partition problem and $O_{\mathcal{F}^{[K]}} < A_{i_1} < A_{i_2} < \dots < A_{i_{k-1}} < S_0$ in this poset T . Conversely, any such normal simplex is the closure of a (semiopen) simplex of the decomposition. Hence, the convex polytope $\mathcal{F}^{[K]}$ is a (nondisjoint) union of such simplices, as expressed by (5.8) of Section 5.5.1.

Now we count the number of integral points in such a simplex: the smallest (in terms of weight) partition (X_i^{\min}) is

$$v \geq \dots \geq v > v - 1 \geq \dots \geq 1 > 0 \geq \dots \geq 0$$

whereas the biggest (X_i^{\max}) is

$$p \geq \dots \geq p > p - 1 \geq \dots \geq p - v + 1 > p - v \geq \dots \geq p - v$$

so that if $Y_i = X_i - X_i^{\min}$, the convex body is defined by

$$p - v \geq Y_1 \geq Y_2 \geq \dots \geq Y_K \geq 0$$

Hence there are as many integral points in this simplex as in a normal simplex of side $p - v$, that is, $\binom{p + K - v}{K}$. ■

Note that in this proof, the assumption on the zero-descent simplex is a very weak condition: up to an adequate index permutation, any of the simplices in the decomposition might be chosen as the zero-descent one (that is, the *reference* simplex) and the proof would be exactly the same. The only difference would be that, in order to get the disjoint union of simplices, we would not necessarily suppress the same faces.

A.3.2. Proof of Section 5.4: Decomposition in q -Dimensional Simplices. In fact, we shall simply modify the previous proof. Let us consider three types of H sets instead of two:

- $H_{i,j}^+$ is the set of points such that $x_i > x_j$.
- $H_{i,j}^0$ is the set of points such that $x_i = x_j$.
- $H_{i,j}^-$ is the set of points such that $x_i < x_j$.

Now, when i and j are dependent ($i < j$), the relation between x_i and x_j can be $x_i > x_j$ or $x_i = x_j$ (but not $x_j < x_i$). As above, we shall now only consider the inequalities (3.1) of the partition problem and afterward make the intersection with inequalities (3.2). The set of points that satisfies inequalities (3.1) is still the (hyper)cone Q . If we write

$$Q = \bigcap_{i < j \text{ dep.}} \left(H_{i,j}^+ \overset{\text{disj.}}{\cup} H_{i,j}^0 \right)$$

and

$$\mathbf{R}^K = \bigcup_{\{e_y\}_{i < j \text{ ind.}} \in \{+, 0, -\}} \left(\bigcap_{i < j \text{ ind.}} H_{i,j}^{e_y} \right)$$

then we get

$$Q = \left(\bigcup_{\{e_y\}_{i < j \text{ ind.}} \in \{+, 0, -\}} \left(\bigcap_{i < j \text{ dep.}} H_{i,j}^{e_y} \right) \right) \cap \left(\bigcup_{\{e_y\}_{i < j \text{ ind.}} \in \{+, 0, -\}} \left(\bigcap_{i < j \text{ ind.}} H_{i,j}^{e_y} \right) \right)$$

So Q is the disjoint union of the different sectors of space defined by the given families of “signs” $(\varepsilon_{ij})_{i < j \text{ dep.}} \in \{+, 0\}$ and $(\varepsilon_{ij})_{i < j \text{ ind.}} \in \{+, 0, -\}$:

$$Q = \bigcup_{(\varepsilon_{ij}) \in \{+, 0, -\}}^{\text{disj.}} \left(\bigcap_{i < j} H_{i,j}^{\varepsilon_{ij}} \right) \tag{A4}$$

Such a sector is an open cone in the linear subspace defined by the equalities $(\varepsilon_{ij} = 0)$ between variables x_i .

As above, if \rightarrow means now $>$ or $=$, this sector is either empty or defined by a sequence of the form

$$x_{i_1} \rightarrow x_{i_2} \rightarrow \dots \rightarrow x_{i_k}$$

Remark. This decomposition can be considered as a *triangulation* of the cone Q , as defined, for example, in ref. 33. In effect, it is written as the disjoint union of “simplicial cones,” that is, cones built on simplices, which satisfy all the axioms of a triangulation.

If we add now the set of inequalities (3.2), the convex polytope of the partition problem is a disjoint union of simplices of the form

$$p \geq x_{i_1} \rightarrow x_{i_2} \rightarrow \dots \rightarrow x_{i_k} \geq 0$$

The closure of this simplex is a q -dimensional normal simplex:

$$\text{Simp}(O_{\mathcal{F}^{[K]}}, A_{i_1}, A_{i_2}, \dots, A_{i_{q-1}}, S_0)$$

where $q - 1$ is the number of strict inequalities in the above sequence, and where the A_{i_j} are vertices of the graph T of this partition problem and $O_{\mathcal{F}^{[K]}} = A_{i_1} < A_{i_2} < \dots < A_{i_{q-1}} < S_0$ in this poset T . Conversely, any such normal simplex is the closure of a (semiopen) simplex of the decomposition. We write this semiopen simplex $\text{Simp}^*(O_{\mathcal{F}^{[K]}}, A_{i_1}, A_{i_2}, \dots, A_{i_{q-1}}, S_0)$:

$$\mathcal{F}^{[F]} = \bigcup_{q=1}^K \left(\bigcup_{\substack{O_{\mathcal{F}^{[K]}} < A_{i_1} < A_{i_2} < \dots < A_{i_{q-1}} < S_0 \\ A_{i_j} \in \Gamma_{\mathcal{F}^{[K]}}}^{\text{disj.}}}} \text{Simp}^*(O_{\mathcal{F}^{[K]}}, A_{i_1}, A_{i_2}, \dots, A_{i_{q-1}}, S_0) \right) \tag{A5}$$

Now, as in the previous proof, we count the number of integral points in such a simplex. As above, we prove that there are as many integral points in this simplex as in a q -dimensional normal simplex of side $p - q + 1$, that is, $\binom{p+1}{q}$.

Hence,

$$P_{\mathcal{F}^{[K]}(p)} = \sum_{q=1}^K \left(\bigcup_{\substack{0_{\mathcal{F}^{[K]}} < A_{i_1} < A_{i_2} < \dots < A_{i_{q-1}} < S_0 \\ A_i \in \mathcal{F}^{[K]}}} \binom{p+1}{q} \right) \tag{A.6}$$

Remark. This last decomposition of $\mathcal{F}^{[K]}$ is not a triangulation any longer since there exist faces not all of whose subfaces are in the decomposition (the subfaces corresponding to the inequalities $x_{i_1} = p$ or $x_{i_k} = 0$). However, if we added all the subfaces of all the faces to this decomposition, we would get a triangulation.

A.4. A Geometrical Proof of the Symmetry Property (Section 5.5.4)

Our aim here is to prove that the coefficients a_j have the symmetry property $a_j = a_{M-j}$, and to make precise the value of M .

Notation. For the sake of brevity, we shall use the notation $T_j(p) = \binom{p+K-j}{K}$ instead of $X_{(K)}^{-j}(p)$.

Then $P_{\mathcal{F}^{[K]}} = \sum a_j T_j$.

We shall now use Ehrhart’s reciprocity law: if $\tilde{P}_{\mathcal{F}^{[K]}}(p)$ denotes the number of integral points in the interior of $p\mathcal{F}^{[K]}$, then

$$\tilde{P}_{\mathcal{F}^{[K]}}(p) = (-1)^K P_{\mathcal{F}^{[K]}}(-p) = \sum a_j (-1)^K T_j(-p)$$

The interior is defined by the new inequalities

$$x_i > x_j \quad \text{and} \quad p > x_i > 0$$

We shall use again the notations x_{i_1, \dots, i_d} , $1 \leq i_n \leq k_n$, to emphasize the fact that the partition variables are arranged in a d -dimensional hypersolid array. Then let us define the new set of variables X_{i_1, \dots, i_d} as follows: if δ is the Manhattan distance, in this hypersolid array, between the box i_1, \dots, i_d and the box k_1, \dots, k_d , then

$$X_{i_1, \dots, i_d} = x_{i_1, \dots, i_d} - \delta - 1$$

These new variables will be best understood on the 2-dimensional example of Fig. 15.

Now the X_i have the nice property that they satisfy the inequalities

$$X_i \geq X_j \quad \text{and} \quad p - p_0 \geq X_i \geq 0$$

$x_{1,1} - k_1 - k_2 + 1$	$x_{1,2} - k_1 - k_2 + 2$...	$x_{1,k_2-1} - k_1 - 1$	$x_{1,k_2} - k_1$
$x_{2,1} - k_1 - k_2 + 2$	$x_{2,2} - k_1 - k_2 + 3$...	$x_{2,k_2-1} - k_1$	$x_{2,k_2} - k_1 + 1$
\vdots	\vdots		\vdots	\vdots
$x_{k_1-1,1} - k_2 - 1$	$x_{k_1-1,2} - k_2$...	$x_{k_1-1,k_2-1} - 3$	$x_{k_1-1,k_2} - 2$
$x_{k_1,1} - k_2$	$x_{k_1,2} - k_2 + 1$...	$x_{k_1,k_2-1} - 2$	$x_{k_1,k_2} - 1$

Fig. 15. New set of variables X_i ($3 \rightarrow 2$ problem).

where

$$p_0 = k_1 + k_2 + \dots + k_d - d + 2$$

These inequalities are the same as (3.1) and (3.2) except that p is different. Then the number of integral points in the interior of $p\mathcal{F}^{[K]}$ is $P_{\mathcal{F}^{[K]}}(p - p_0) = \sum a_j T_j(p - p_0)$.

Then

$$\sum a_j (-1)^K T_j(-p) = \sum a_j T_j(p - p_0)$$

Now the binomial definition of T_j enables us to write $T_j(p - p_0) = (-1)^K T_{M-j}(-p)$, where $M = k_1 \cdot k_2 \cdot \dots \cdot k_d - (k_1 + \dots + k_d) + d - 1$. Replacing this equality in the right-hand side of the above equality, we get $\sum a_j T_j = \sum a_j T_{M-j}$, or better

$$\sum a_j T_j = \sum a_{M-j} T_j$$

By unicity of the coefficients a_j , we finally have

$$a_j = a_{M-j} \blacksquare$$

APPENDIX B. ASYMPTOTIC BEHAVIOR AND k -DIMENSIONAL CATALAN NUMBERS

We see in this Appendix that the number of normal simplices of a partition problem normal decomposition is given by the asymptotic behavior of $P_{\mathcal{F}^{[K]}}(p)$. Indeed, for any j , $\binom{p-j+K}{K} \sim p^K/K!$ when p goes to infinity. Hence

$$P_{\mathcal{F}^{[K]}}(p) \sim \left(\sum_{j \geq 0} a_j \right) \frac{p^K}{K!} \tag{B.1}$$

and $\sum_{j \geq 0} a_j$ is the number of simplices. Then the number of simplices is given by the leading term of Ehrhart's polynomial times $K!$.

For instance, let us consider the $3 \rightarrow 2$ problem $k \times l$. Now, $p \rightarrow \infty$ gives the number of simplices:

$$\sum_{j \geq 0} a_j = (kl)! \frac{1! 2! \cdots (k-1)!}{l! (l+1)! \cdots (l+k-1)!} \tag{B.2}$$

But we know that this number is also the number of walks in the graph of this partition problem. Now this graph is composed of the integral points of a $2 \rightarrow 1$ partition problem convex polytope, that is, a k -dimensional normal simplex of side l (or an l -dimensional simplex of side k). This is a generalization of the well-known *Dyck walks* of combinatorics, that is, discrete walks in a triangle of side l .

Hence, this work gives as a corollary the number of generalized k -dimensional Dyck walks, called the generalized k -dimensional Catalan number—since classical Dyck walks are counted by the Catalan numbers $(2l)!/[l!(l+1)!]$. This combinatorial problem is also known as the generalized ballot problem.

Note that this formula for the number of Dyck walks had already been derived by Young in 1927.⁽²⁷⁾ A nice proof can also be derived from the hook formula by Frame, Robinson, and Thrall (for a nice presentation of this result, see ref. 34). We have a direct combinatorial proof of this result, too.

APPENDIX C. ANALYTICAL BEHAVIOR OF THE a_j FOR THE $3 \rightarrow 2$ PROBLEM

We are going to give an approximate expression for a_j for “small” j , in a sense that will be defined below.

We shall use the notation $a_j(k, l)$ for the coefficients of the $3 \rightarrow 2$ problem $k \times l$.

First, let us prove that, for j “small,”

$$\log W_{k,l,j}^{3 \rightarrow 2} \simeq \log \sum_{i=0}^j a_i(k, l) \tag{C.1}$$

For a given j ,

$$\begin{aligned} W_{k,l,j}^{3 \rightarrow 2} &= \sum_{i=0}^j a_i(k, l) \binom{kl+j-i}{kl} \\ &\leq \left[\sum_{i=0}^j a_i(k, l) \right] \binom{kl+j}{kl} \end{aligned}$$

and, obviously, $\sum_{i=0}^j a_i(k, l) \leq W_{k,l,j}^{3 \rightarrow 2}$.

Hence,

$$\log \sum_{i=0}^j a_i(k, l) \leq \log W_{k,l,j}^{3 \rightarrow 2} \leq \log \sum_{i=0}^j a_i(k, l) + \log \binom{kl+j}{kl}$$

Thanks to the Stirling formula (or Section 6.1.2),

$$\begin{aligned} \log \binom{kl+j}{kl} &= \log(kl+j)! - \log(kl)! - \log j! \\ &\simeq (kl+j) \log(kl+j) - kl \log(kl) - j \log j \\ &\simeq (kl+j) \log(kl) - kl \log(kl) - j \log j \\ &\simeq j \log(kl/j) \\ &\leq j \log(kl) \end{aligned}$$

Now, the approximative result for $S^{3 \rightarrow 2}$ (Section 7.1) gives, using again the results of Section 6.1.2, applied to the factorial functions of order 2,

$$\log W_{k,l,j}^{3 \rightarrow 2} \simeq \text{Cst} \cdot (kl)$$

Hence, the result given at the beginning of this Appendix is valid as long as $j \log kl \ll kl$, that is $j \ll kl/\log kl$. This is what we call “ j small.” This covers, in particular, the “diagonal” case $j = k = l$.

Now, we shall see that, in the same domain of j 's.

$$\log \sum_{i=0}^j a_i(k, l) \simeq \log a_j(k, l) \tag{C.2}$$

Indeed, let us assume that when j is “small,” $a_j(k, l)$ is an increasing function of j (see discussion below). Then

$$\cdot \quad a_j(k, l) \leq \sum_{i=0}^j a_i(k, l) \leq (j+1) a_j(k, l)$$

Hence,

$$\log a_j(k, l) \leq \log \sum_{i=0}^j a_i(k, l) \leq \log(j+1) + \log a_j(k, l)$$

But in this domain of j 's, $\log \sum_{i=0}^j a_i(k, l) \simeq \text{Cst} \cdot (kl)$ and $\log(j + 1)$ is infinitely small with respect to $\log \sum_{i=0}^j a_i(k, l)$.

As a conclusion,

$$\log W_{k,l,j}^{3 \rightarrow 2} \simeq \log a_j(k, l) \tag{C.3}$$

This means that, in this range of j 's, the enumeration is asymptotically dominated by a_j , the number of simplices with exactly j descents in the configuration space. [Looking more closely at the proof, we would see that, for $j \in [1 \dots j_0]$, the convergence is uniform for $(k, l) \rightarrow \infty$.]

Note the existence of a similar relation for any partition problem, or any standard tiling enumeration problem, as soon as the increasing character of the a_j is established. However, except for the $3 \rightarrow 2$ problems, where it can be proved directly from the MacMahon enumeration functions, and for the $4 \rightarrow 3$ problems, where it can be conjectured thanks to the approximate enumeration functions, this increasing character can so far generally be verified only on examples.

Thanks to this last relation and to the asymptotic behavior of the generalized factorial of order 2, we shall be able to give the analytical behavior of the a_j :

$$\begin{aligned} \log a_{\mu k}(k, \alpha k) &\simeq \log W_{k, \alpha k, \mu k}^{3 \rightarrow 2} \\ &\simeq \frac{k^2}{2} [(1 + \alpha + \mu)^2 \log(1 + \alpha + \mu) + \mu^2 \log \mu \\ &\quad + \alpha^2 \log \alpha - (\alpha + \mu)^2 \log(\alpha + \mu) \\ &\quad - (1 + \alpha)^2 \log(1 + \alpha) - (1 + \mu)^2 \log(1 + \mu)] \\ &= \frac{k^2}{2} f_x(\mu) \end{aligned}$$

For instance, the function $f_1(\mu)$ is given in Fig. 16.

[The convergence $(2/k^2) \log a_{\mu k}(k, \alpha k) \rightarrow f_x(\mu)$ is also uniform for $(\alpha, \mu) \in C$, C compact subset of $(R_+^*)^2$.]

Moreover,

$$f_x(\mu) = f_\mu(\alpha) = \alpha^2 f_{\mu/\alpha}(1/\alpha) \tag{C.4}$$

These relations are compatible with the symmetries of $W_{k,l,j}^{3 \rightarrow 2}$.

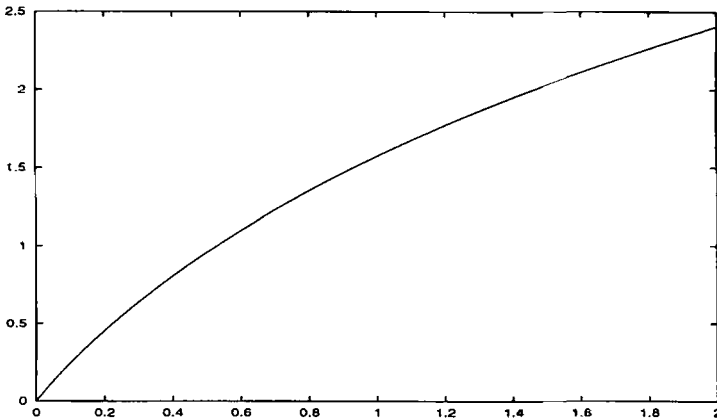

Fig. 16. The function $f_1(\mu)$.

Remark. The entropy per tile (Section 7) can be expressed in a very simple way thanks to these functions:

$$S^{3-2} = \frac{1}{2(1 + \alpha + \mu)} f_{\alpha}(\mu) \tag{C.5}$$

ACKNOWLEDGMENTS

We wish to express our gratitude to M. Widom for fruitful discussions. We are also grateful to J. M. Kantor and V. Reiner for useful comments on the mathematical content of this work.

REFERENCES

1. D. Shechtman, I. Blech, D. Gratias, and J. W. Cahn, Metallic phase with long-range orientational order and no translational symmetry, *Phys. Rev. Lett.* **53**:1951 (1984).
2. D. P. Di Vincenzo and P. J. Steingart, eds., *Quasicrystals, the State of the Art* (World Scientific, Singapore, 1991).
3. F. Hippert and D. Gratias, eds. *Lectures on Quasicrystals* (Les Editions de Physique, 1994).
4. C. Janot, *Quasicrystals, a Primer* (Oxford Science Publications, 1994).
5. C. Janot and R. Mosseri, eds., *Proceedings of the 5th International Conference on Quasicrystals* (World Scientific, Singapore, 1995).
6. J. Friedel and F. Denoyer, Les quasicristaux de AlLiCu comme alliages de Hume Rothery, *C. R. Acad. Sci. Paris* **305**(II):171 (1987).
7. V. Elser, Solution of the dimer problem on an hexagonal lattice with boundary, *J. Phys. A Math. Gen.* **17**:1509 (1984).
8. C. L. Henley, Random tiling models, in *Quasicrystals, the State of the Art*, D. P. Di Vincenzo and P. J. Steingart, eds. (World Scientific, Singapore, 1991), p. 429.

9. N. G. De Bruijn, Dualization of multigrids, *J. Phys. France* **47**:C3-9 (1986).
10. R. Mosseri, F. Bailly, and C. Sire, Configurational entropy in random tiling models, *J. Non-Cryst. Solids* **153&154**:201 (1993).
11. R. Mosseri and F. Bailly, Configurational entropy in octagonal tiling models, *Int. J. Mod. Phys. B* **7(6&7)**:1427 (1993).
12. V. Elser, Comment on "Quasicrystals: A new class of ordered structures," *Phys. Rev. Lett.* **54**:1730 (1985).
13. M. Duneau and A. Katz, Quasiperiodic patterns, *Phys. Rev. Lett.* **54**:2688 (1985).
14. A. P. Kalugin, A. Y. Kitaev, and L. S. Levitov, $Al_{0.86}Mn_{0.14}$: A six-dimensional crystal, *JETP Lett.* **41**:145 (1985); A. P. Kalugin, A. Y. Kitaev, and L. S. Levitov, 6-Dimensional properties of $Al_{0.86}Mn_{0.14}$, *J. Phys. Lett. France* **46**:L601 (1985).
15. W. Li, H. Park, and M. Widom, Phase diagram of a random tiling quasicrystal, *J. Stat. Phys.* **66(1/2)**:1 (1992).
16. G. H. Wannier, Anti-ferromagnetism. The triangular Ising net, *Phys. Rev.* **79**:357 (1950); *Phys. Rev. B* **7**:5017 (E) (1973).
17. H. W. J. Blöte and H. J. Hilhorst, Roughening transitions and zero-temperature triangular Ising anti-ferromagnet, *J. Phys. A Math. Gen.* **15**:L631 (1982).
18. M. Widom, Bethe ansatz solution of the square-triangle random tiling model, *Phys. Rev. Lett.* **70**:2094 (1993).
19. P. A. Kalugin, The square-triangle random-tiling model in the thermodynamic limit, *J. Phys. A: Math. Gen.* **27**:3599 (1994).
20. R. Mosseri and J. F. Sadoc, Glass like properties in quasicrystals, in *Proceedings of the 5th International Conference on Quasicrystals*, C. Janot and R. Mosseri, eds. (World Scientific, Singapore, 1995), p. 747.
21. P. A. MacMahon, *Combinatory Analysis* (Cambridge University Press, Cambridge, 1916).
22. E. Ehrhart, Nombre de points entiers d'un tétraèdre, *C. R. Acad. Sci. Paris* **258(1)**:3945-3948 (1964).
23. E. Ehrhart, Démonstration de la loi de réciprocité pour le polyèdre convexe entier, *C. R. Acad. Sci. Paris* **265(1)**:5-7 (1967).
24. M. Brion, Points entiers dans les polytopes convexes, *Séminaire Bourbaki* **46** (March 1994): Talk 780.
25. I. Gessel and G. Viennot, Binomial determinants, paths, and hook length formulae, *Adv. Math.* **58**:300-321 (1985).
26. J. M. Stembridge, Non-intersecting paths, Pfaffians, and plane partitions, *Adv. Math.* **83**:96-131 (1990).
27. A. Young, On quantitative substitutional analysis, *Proc. Lond. Math. Soc.* **2** **28**:255-292 (1927).
28. E. W. Barnes, The theory of the G -functions, *Q. J. Math.* **XXXI**:264-314 (1900).
29. B. Sturmfels and G. M. Ziegler, Extension spaces of oriented matroids, *Discrete Computational Geom.* **10**:23-45 (1993).
30. G. H. Hardy and E. M. Wright, *An Introduction to the Theory of Numbers* (Oxford University Press, Oxford, 1938).
31. L. Comtet, *Analyse Combinatoire* (Presses Universitaires de France, Paris, 1970).
32. H. S. M. Coxeter, *Regular Polytopes* (Dover, New York, 1973).
33. G. M. Ziegler, *Lectures on Polytopes* (Springer-Verlag, Berlin, 1995).
34. B. E. Sagan, *The Symmetric Group* (Wadsworth and Brooks/Cole, Pacific Grove, California, 1991).
35. R. P. Stanley, Ordered structures and partitions. *Mem. AMS* **119** (1972).
36. R. P. Stanley, *Enumerative Combinatorics* (Wadsworth and Brooks/Cole, Pacific Grove, California, 1986), Vol. 1.